

Fresno County Employees' Retirement Association

Cumulative Performance Comparisons

Period Ending: March 31, 2008

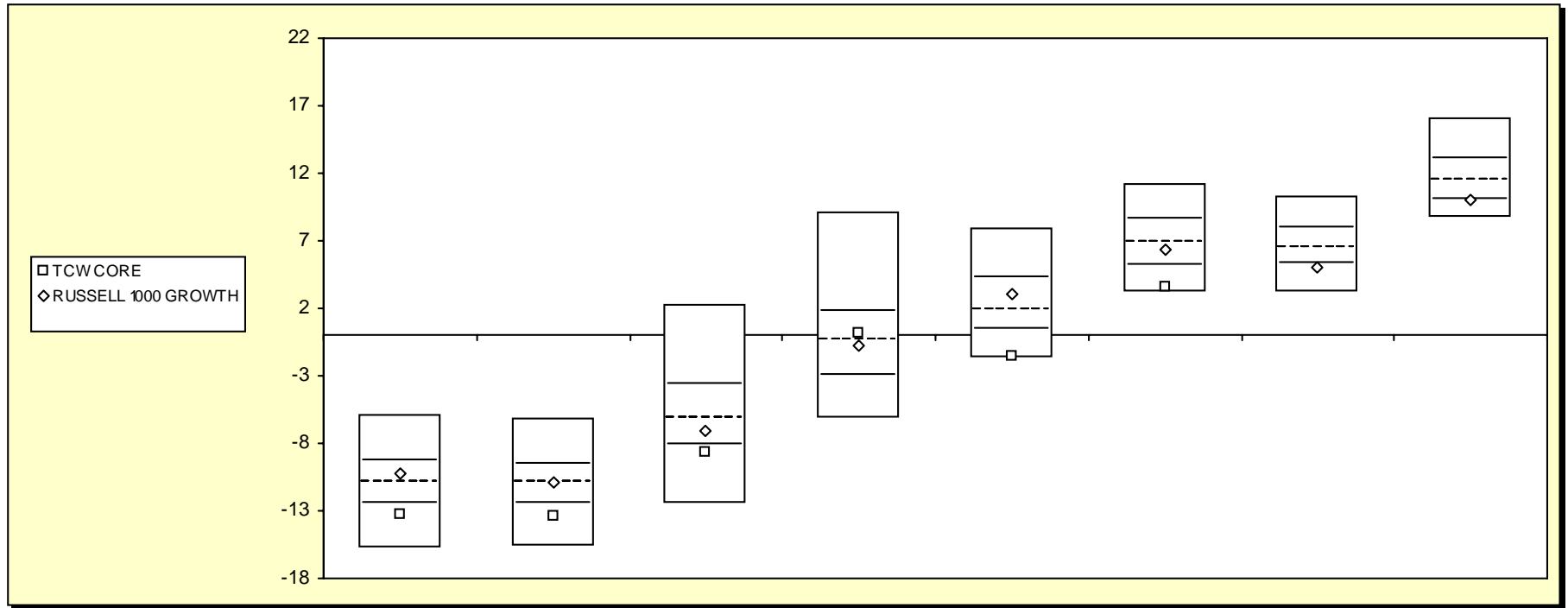

Equity Style - Large Growth

	Last Quarter	Two Quarters	Three Quarters	One Year	Two Years	Three Years	Four Years	Five Years
	Return Rank	Return Rank	Return Rank	Return Rank	Return Rank	Return Rank	Return Rank	Return Rank
5th Percentile	-5.9	-6.2	2.3	9.1	7.9	11.2	10.3	16.1
25th Percentile	-9.3	-9.6	-3.7	1.8	4.3	8.5	8.0	13.0
50th Percentile	-10.9	-10.9	-6.1	-0.4	1.9	6.8	6.5	11.5
75th Percentile	-12.5	-12.5	-8.1	-3.0	0.4	5.2	5.3	10.0
95th Percentile	-15.8	-15.6	-12.5	-6.2	-1.7	3.2	3.2	8.7
TCW CORE	-13.3 80	-13.4 81	-8.6 77	0.2 43	-1.5 93	3.5 92		
RUSSELL 1000 GROWTH	-10.2 39	-10.9 50	-7.1 63	-0.7 54	3.1 37	6.3 58	5.0 78	10.0 76

Fresno County Employees' Retirement Association

Consecutive Performance Comparisons

Period Ending: March 31, 2008

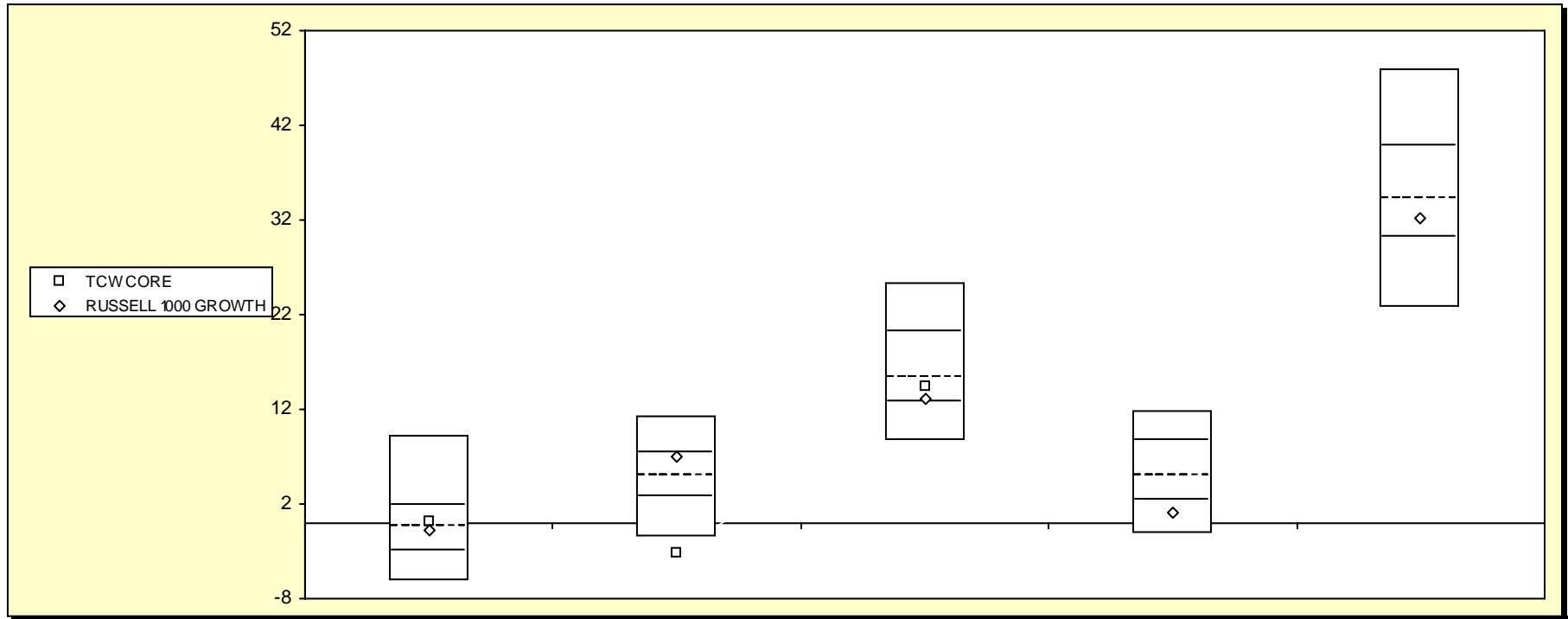

Equity Style - Large Growth

	March 2008		March 2007		March 2006		March 2005		March 2004	
	Return	Rank	Return	Rank	Return	Rank	Return	Rank	Return	Rank
5th Percentile	9.1		11.3		25.3		11.8		47.9	
25th Percentile	1.8		7.3		20.2		8.6		39.7	
50th Percentile	-0.4		5.0		15.3		5.0		34.2	
75th Percentile	-3.0		2.7		12.8		2.3		30.1	
95th Percentile	-6.2		-1.4		8.7		-1.2		22.7	
TCW CORE	0.2	43	-3.2	97	14.3	59				
RUSSELL 1000 GROWTH	-0.7	54	7.1	28	13.2	72	1.2	81	32.2	62

Fresno County Employees' Retirement Association

Consecutive Annual - Five Year

Period Ending: March 31, 2008

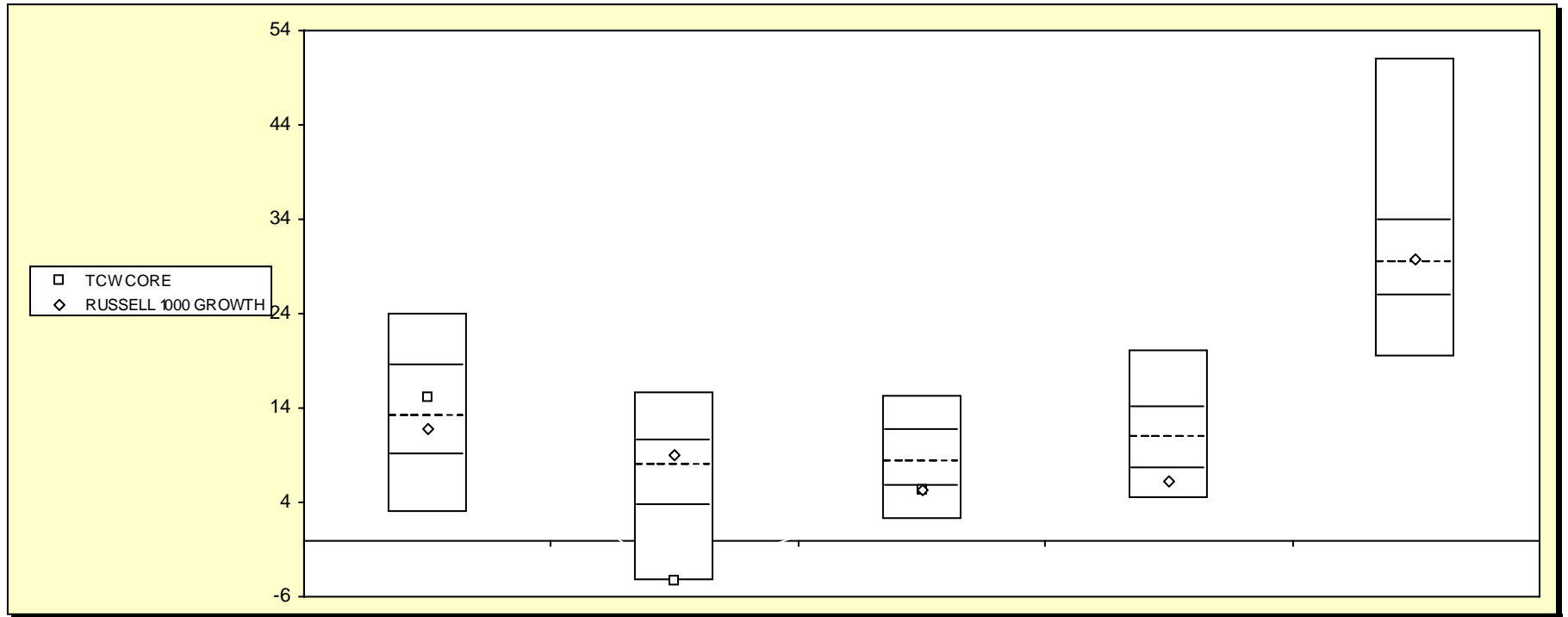

Equity Style - Large Growth

	December 2007		December 2006		December 2005		December 2004		December 2003	
	Return	Rank	Return	Rank	Return	Rank	Return	Rank	Return	Rank
5th Percentile	24.0		15.6		15.3		20.1		51.0	
25th Percentile	18.4		10.5		11.6		13.9		33.7	
50th Percentile	13.1		7.9		8.3		10.9		29.4	
75th Percentile	9.0		3.7		5.7		7.5		25.8	
95th Percentile	2.9		-4.3		2.1		4.4		19.4	
TCW CORE	15.2	40	-4.3	95	5.2	78				
RUSSELL 1000 GROWTH	11.8	58	9.1	38	5.3	78	6.3	83	29.7	48

Fresno County Employees' Retirement Association

Equity Only Summary Statistics

Period Ending: March 31, 2008

TCW CORE

	Portfolio	RUSSELL 1000 GROWTH
Total Number of Securities	130	687
Total Market Value	90,928,220	
Average Market Capitalization (000's)	65,416,992	66,240,000
Equity Segment Yield	1.60	1.29
Equity Segment Price/Earnings Ratio	23.36	17.22
Equity Segment Beta	1.11	1.16
Price/Book Ratio	4.66	4.78
5 Year Earnings Growth	20.7%	29.1%

Ten Largest Holdings

Security	Market Value	Weight
MICROSOFT CORP	3,493,578	3.84
CISCO SYS INC	2,293,368	2.52
HEWLETT PACKARD CO	1,935,984	2.13
PEPSICO INC	1,776,120	1.95
MGM MIRAGEINC	1,504,512	1.65
GOOGLE INC	1,497,598	1.65
INTEL CORP	1,399,998	1.54
QUALCOMM INC	1,365,300	1.50
ORACLE CORP	1,328,124	1.46
INTERNATIONAL BUSINESS MACHS	1,289,568	1.42

Ten Best Performers

Security	Return	Weight
CELGENE CORP	32.6	0.79
YAHOO INC	24.4	0.58
BEA SYS INC	21.4	0.62
GENENTECH INC	21.0	0.69
SOUTHWESTERN ENERGY CO	20.9	0.79
XTO ENERGY INC	20.7	0.94
ROSS STORES INC	17.6	0.66
GILEAD SCIENCES INC	12.0	0.85
WAL MART STORES INC	11.4	1.08
STEEL DYNAMICS INC	11.1	0.52

Ten Worst Performers

Security	Return	Weight
SCHERING PLOUGH CORP	-45.7	0.41
UNITEDHEALTH GROUP INC	-40.9	0.70
AUTODESK INCORPORATED COM STK NPV	-36.7	0.19
GOOGLE INC	-36.3	1.65
CYPRESS SEMICONDUCTOR CORP	-34.5	0.68
NII HLDGS INC CL B NEW	-34.2	0.61
MERCK + CO INC	-34.1	0.60
BE AEROSPACE INC	-33.9	0.68
CERNER CORP	-33.9	0.60
INTERCONTINENTALEXCHANGE INC	-32.2	0.30

Fresno County Employees' Retirement Association

Portfolio Characteristics - Equity

Period Ending: March 31, 2008

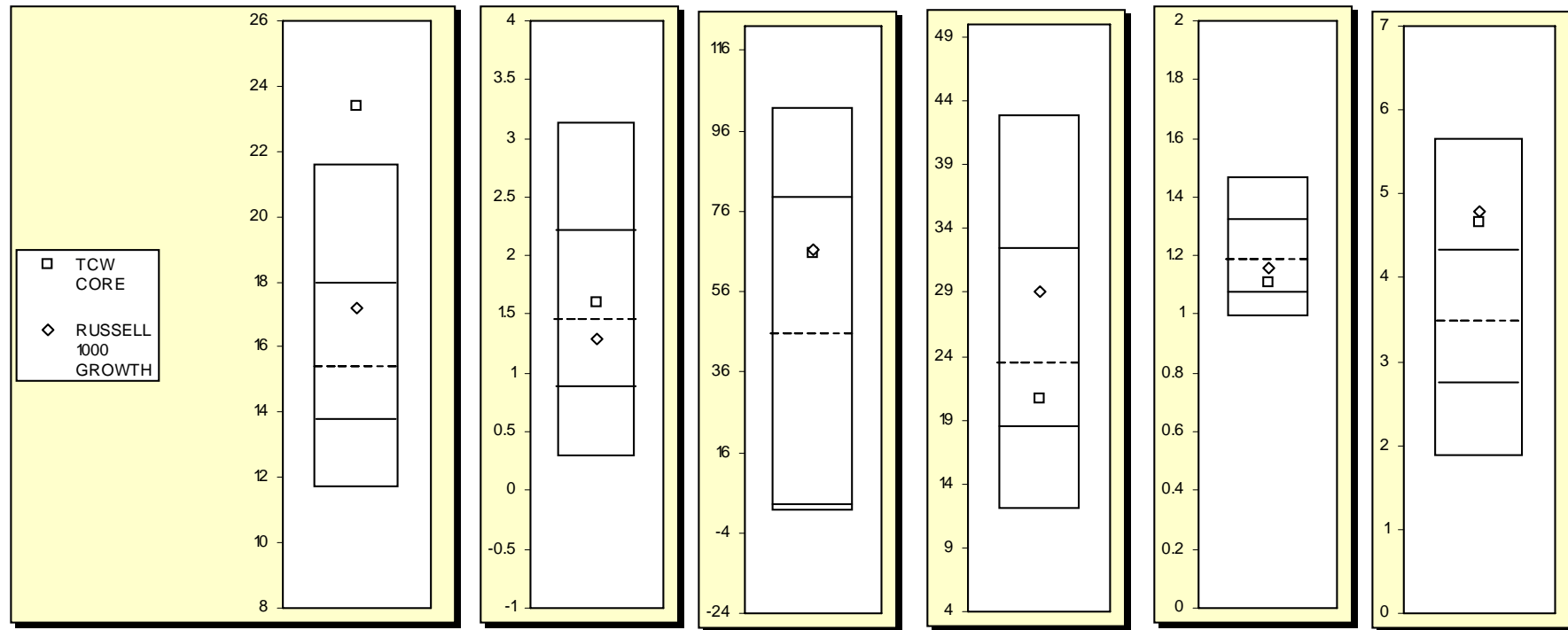

	Price/Earnings Ratio		Dividend Yield		Capitalization		5 Year Earnings		Beta		Price/Book Ratio	
	Value	Rank	Value	Rank	Value	Rank	Value	Rank	Value	Rank	Value	Rank
<i>Equity Funds - Equity Only</i>												
5th Percentile	21.57		3.13		101.51		42.95		1.47		5.66	
25th Percentile	17.93		2.20		78.86		32.34		1.32		4.32	
50th Percentile	15.38		1.45		45.26		23.34		1.18		3.47	
75th Percentile	13.75		0.88		2.83		18.43		1.07		2.72	
95th Percentile	11.66		0.28		1.13		11.93		0.99		1.86	
TCW CORE	23.36	3	1.60	45	65.42	35	20.68	64	1.11	66	4.66	20
RUSSELL 1000 GROWTH	17.22	32	1.29	57	66.24	34	29.12	34	1.16	55	4.78	18

Fresno County Employees' Retirement Association

Top Ten Holding

Period Ending: March 31, 2008

As Of 6/30/06	
PROGRESSIVE COMPANY	8.8%
GOOGLE INC.	6.4%
NETWORK APPLIANCE, INC.	6.2%
SCHLUMBERGER LTD	5.8%
EBAY INCORPORATED	5.8%
GENENTECH INCORPORATED	5.2%
AMAZON. COM CORPORATION	5.2%
COUNTRYWIDE FINANCIAL CORP.	4.9%
QUALCOMM, INC.	4.7%
SLM CORPORATION	4.5%
Top Ten Total:	57.5%

As Of 9/30/06	
GOOGLE INC.	7.3%
PROGRESSIVE COMPANY	7.1%
QUALCOMM, INC.	6.7%
NETWORK APPLIANCE, INC.	6.6%
SCHLUMBERGER LTD	5.6%
GENENTECH INCORPORATED	5.3%
SLM CORPORATION	4.7%
COUNTRYWIDE FINANCIAL CORP.	4.5%
AMAZON. COM CORPORATION	4.3%
EBAY INCORPORATED	4.1%
Top Ten Total:	56.2%

As Of 12/31/06	
QUALCOMM, INC.	8.3%
GOOGLE 'A'	7.5%
NETWORK APPLIANCE, INC.	6.7%
PROGRESSIVE COMPANY	6.7%
SCHLUMBERGER LTD	6.1%
SLM CORPORATION	5.9%
COUNTRYWIDE FINANCIAL CORP.	5.3%
AMAZON. COM CORPORATION	5.1%
GENENTECH INCORPORATED	5.0%
EBAY INCORPORATED	4.1%
Top Ten Total:	60.6%

As Of 3/31/07	
QUALCOMM, INC.	9.8%
SCHLUMBERGER LTD	9.0%
GOOGLE INC.	6.9%
NETWORK APPLIANCE, INC.	6.6%
AMAZON. COM CORPORATION	6.4%
PROGRESSIVE COMPANY	5.9%
EBAY INCORPORATED	4.5%
COUNTRYWIDE FINANCIAL CORP.	4.1%
GENENTECH INCORPORATED	4.0%
SALESFORCE.COM	4.0%
Top Ten Total:	61.2%

As Of 6/30/07	
SCHLUMBERGER LTD	9.9%
QUALCOMM, INC.	8.9%
AMAZON. COM CORPORATION	8.7%
GOOGLE INC.	7.1%
PROGRESSIVE COMPANY	5.8%
SALESFORCE.COM	5.5%
NETWORK APPLIANCE, INC.	4.7%
AUTODESK INCORPORATED	4.4%
COUNTRYWIDE FINANCIAL CORP.	4.0%
COMMERCE BANCORP INCORPORATED	3.9%
Top Ten Total:	62.9%

As Of 9/30/07	
QUALCOMM, INC.	8.6%
SCHLUMBERGER LTD	7.8%
GOOGLE INC.	7.6%
AMAZON. COM CORPORATION	6.9%
SALESFORCE.COM	6.5%
EBAY INCORPORATED	4.7%
AUTODESK INCORPORATED	4.6%
ALLEGHENY TECHNOLOGIES	4.2%
GENERAL ELECTRIC CO.	4.2%
PROGRESSIVE COMPANY	4.1%
Top Ten Total:	59.1%

As Of 12/31/07	
QUALCOMM, INC.	7.9%
SALESFORCE.COM	7.8%
SCHLUMBERGER LTD	7.2%
GOOGLE INC.	7.2%
AMAZON. COM CORPORATION	6.7%
GENZYME	4.6%
AUTODESK INCORPORATED	4.5%
INTERCONTINENTAL EXCHANGE	4.1%
PROGRESSIVE COMPANY	4.0%
CH ROBINSON WORLDWIDE	4.0%
Top Ten Total:	58.1%

As Of 3/31/08	
MICROSOFT CORP	3.8%
CISCO SYS INC	2.5%
HEWLETT PACKARD CO	2.1%
PEPSICO INC	2.0%
MGM MIRAGEINC	1.7%
GOOGLE INC	1.6%
INTEL CORP	1.5%
QUALCOMM INC	1.5%
ORACLE CORP	1.5%
INTERNATIONAL BUSINESS MACHS	1.4%
Top Ten Total:	19.7%

Fresno County Employees' Retirement Association

Equity Only Summary Statistics Charts

Period Ending: March 31, 2008

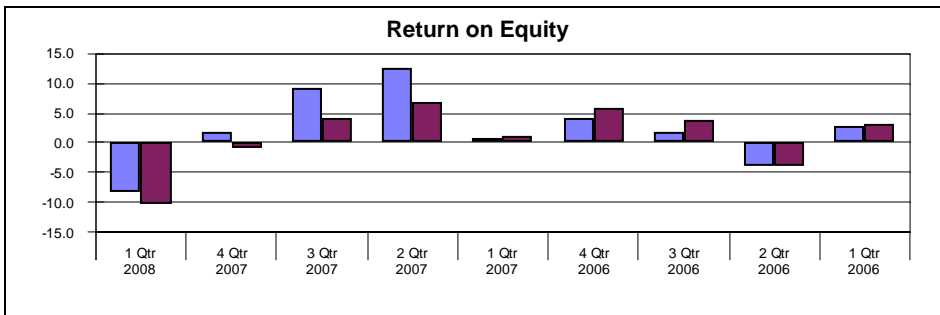
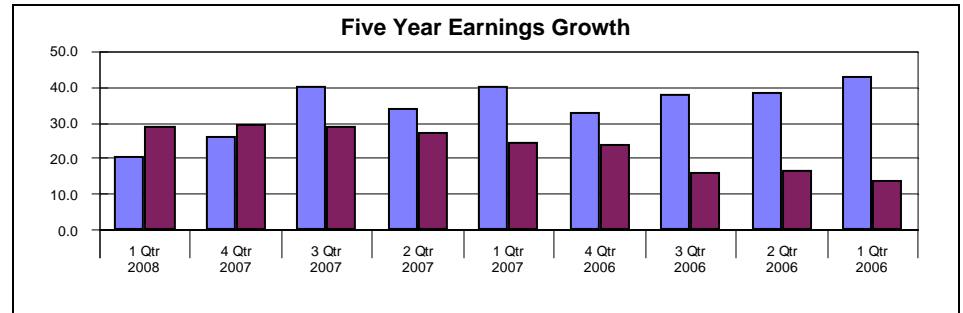
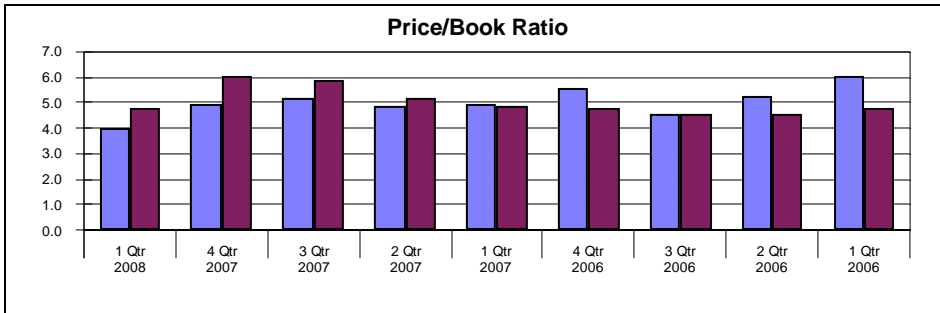
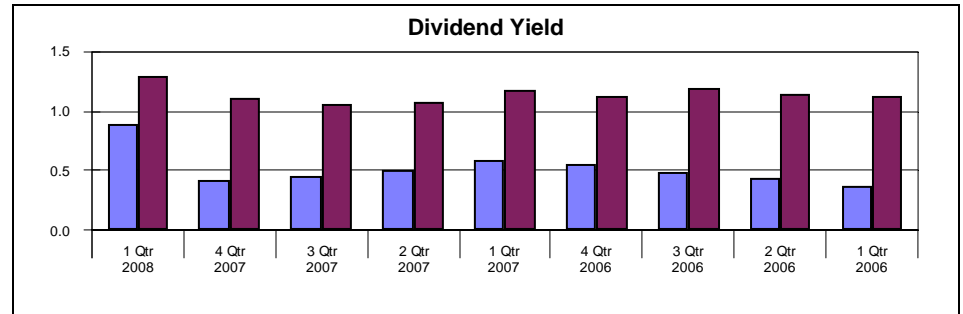
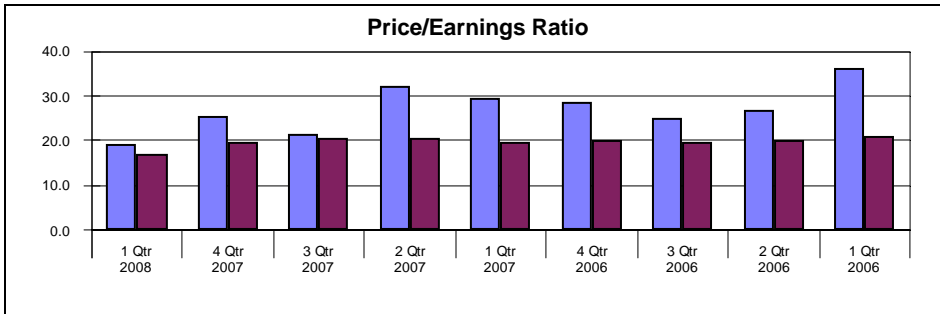
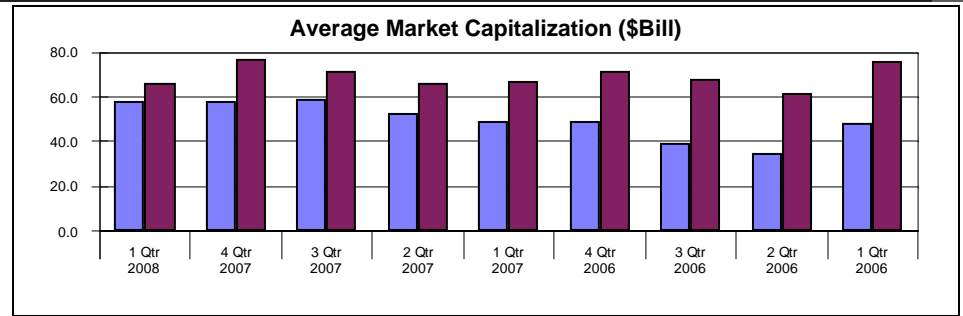
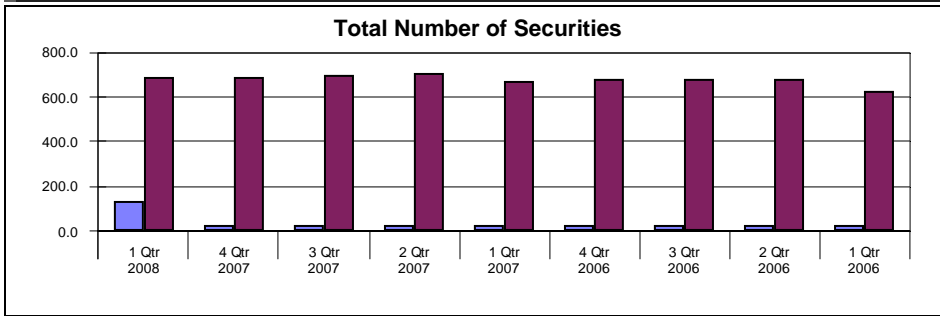

TCW CORE
RUSSELL 1000 GROWTH

Fresno County Employees' Retirement Association

Equity Only Sector Analysis Quarterly

Period Ending: March 31, 2008

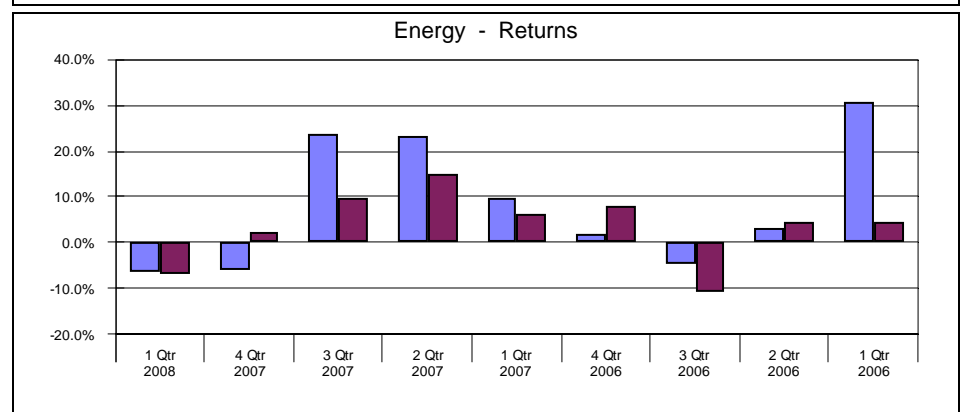
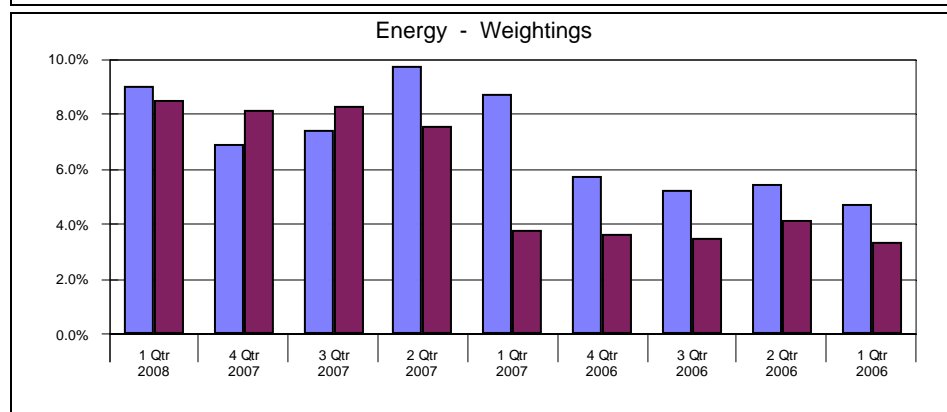
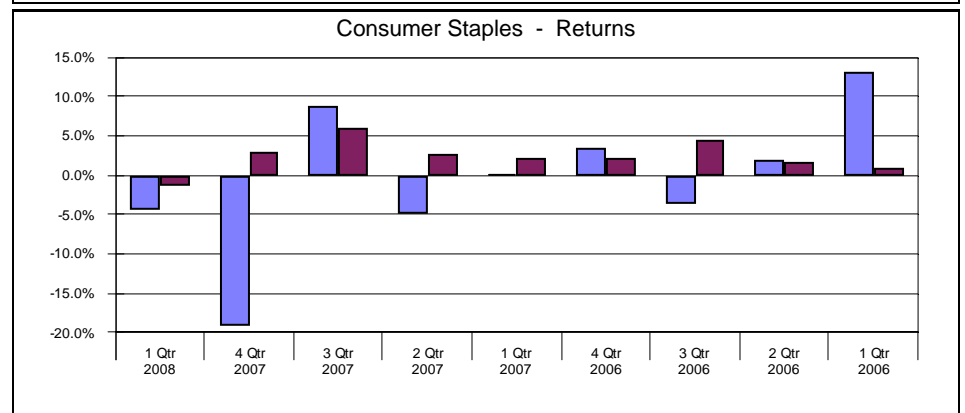
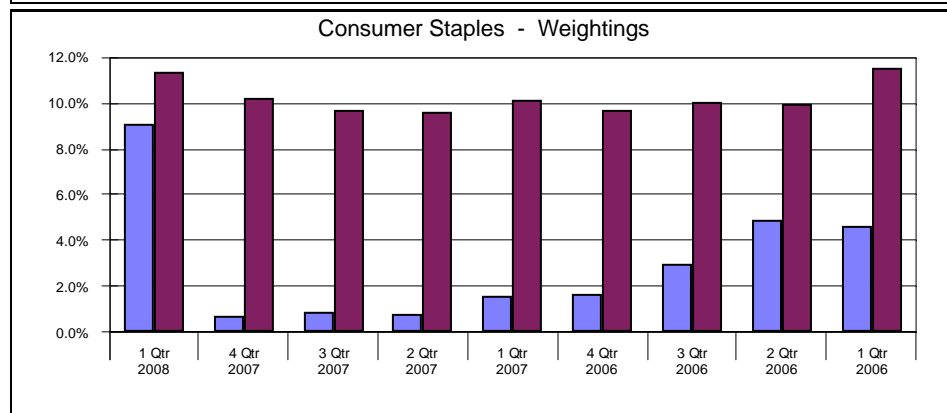
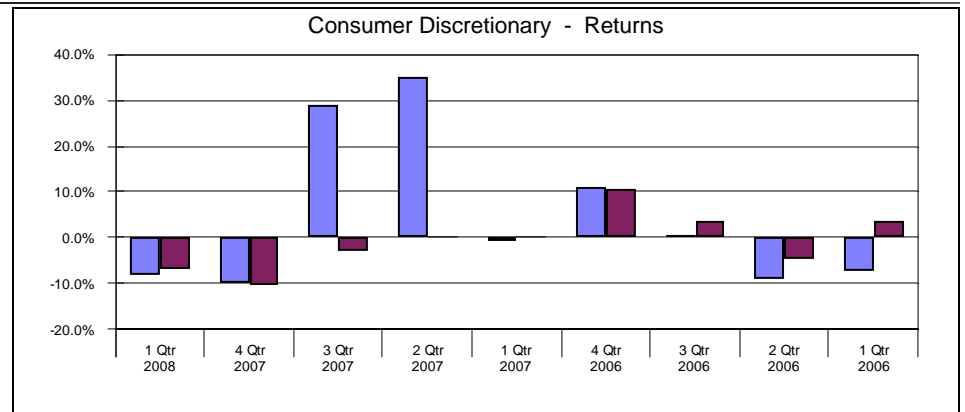
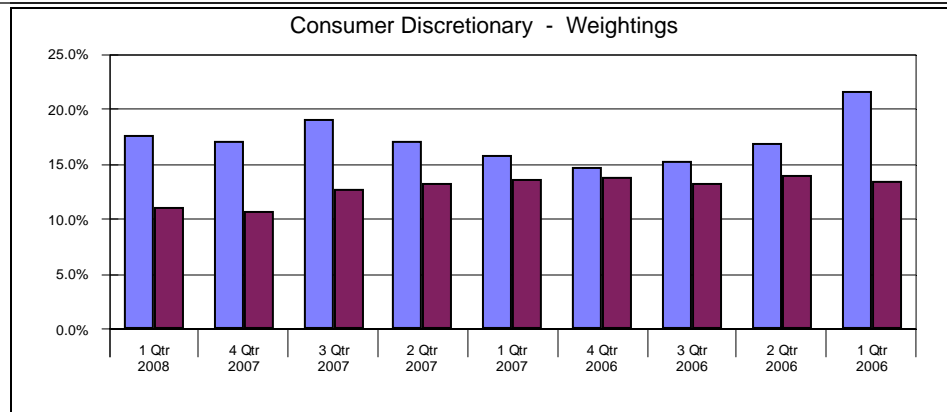

TCW CORE

RUSSELL 1000 GROWTH

Fresno County Employees' Retirement Association

Equity Only Sector Analysis Quarterlyly

Period Ending: March 31, 2008

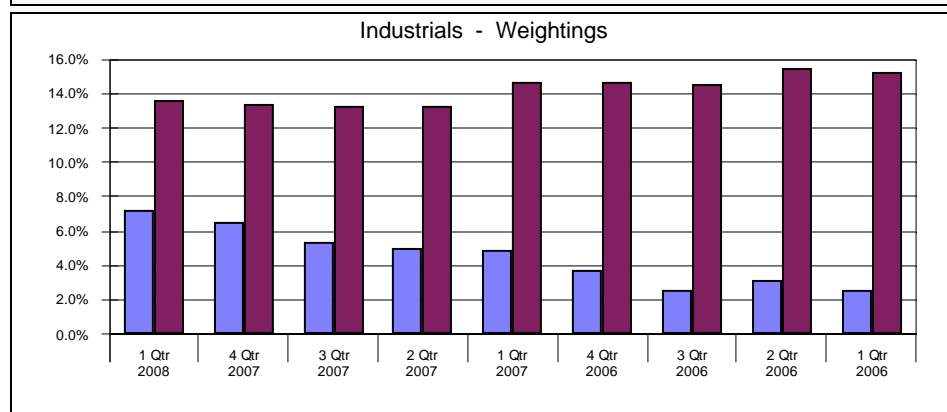
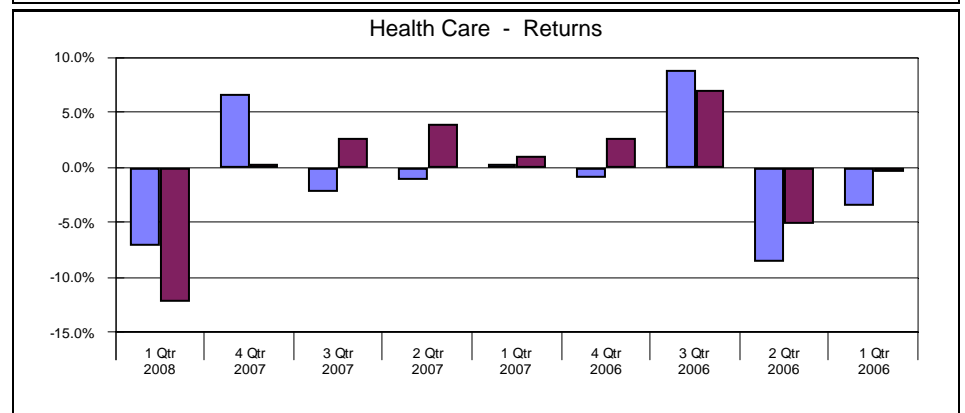
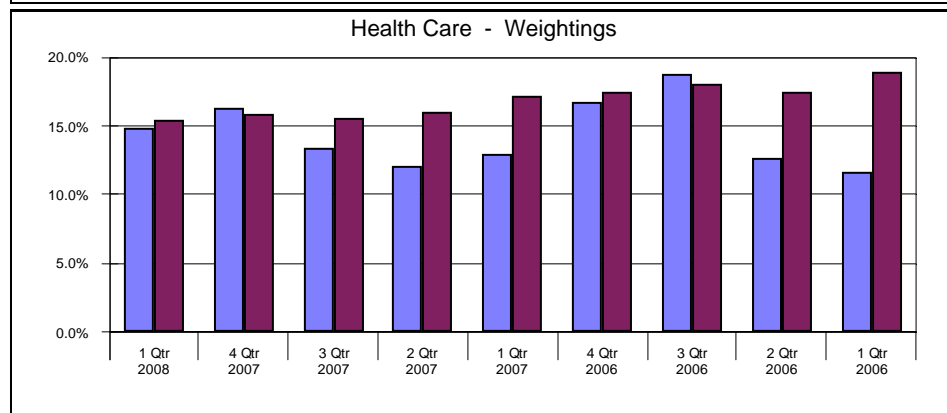
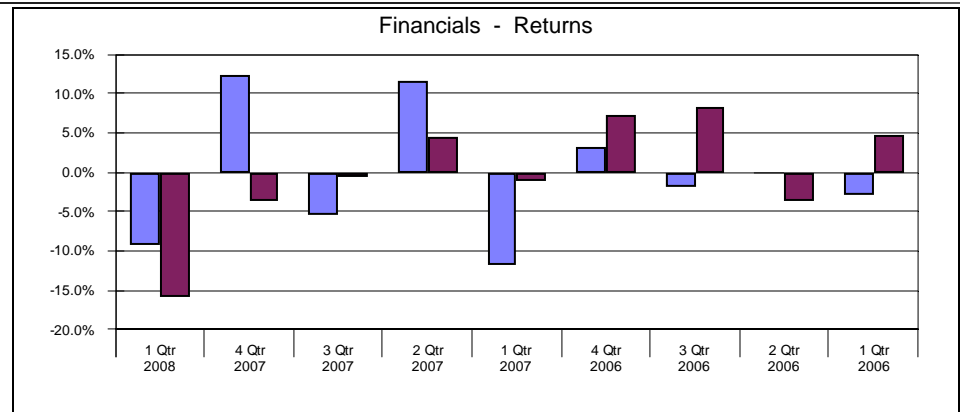
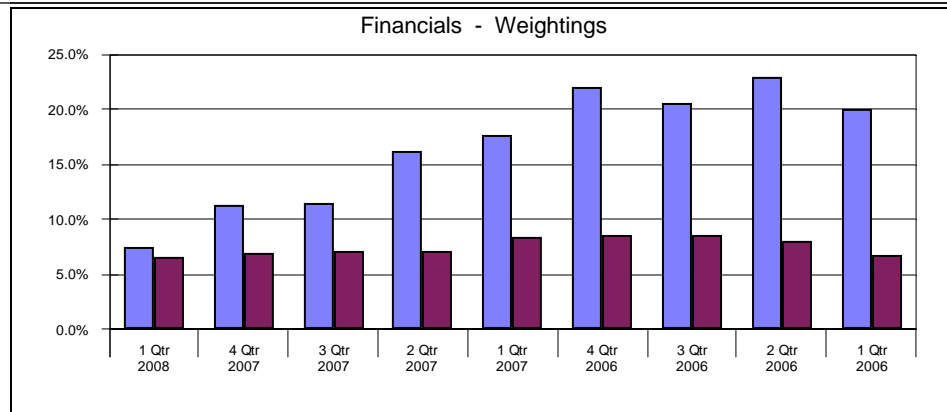

TCW CORE

RUSSELL 1000 GROWTH

Fresno County Employees' Retirement Association

Equity Only Sector Analysis Quarterly

Period Ending: March 31, 2008

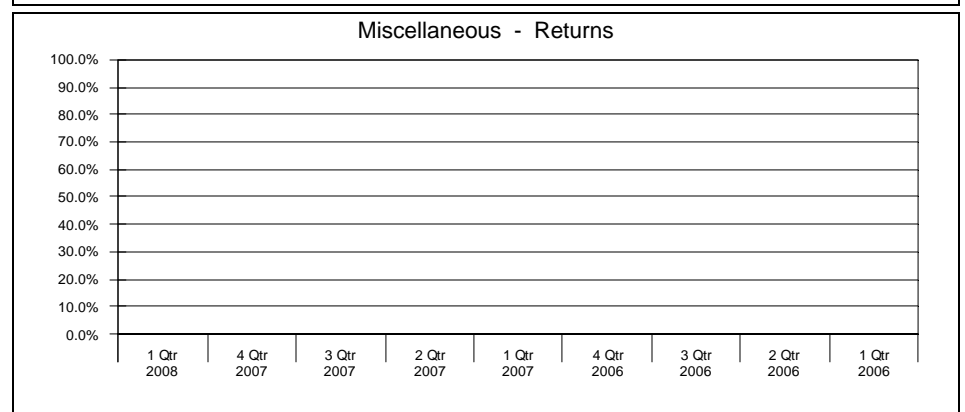
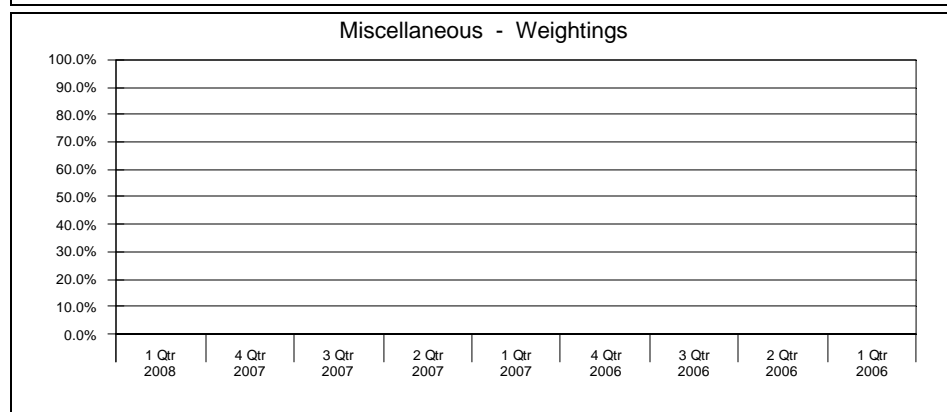
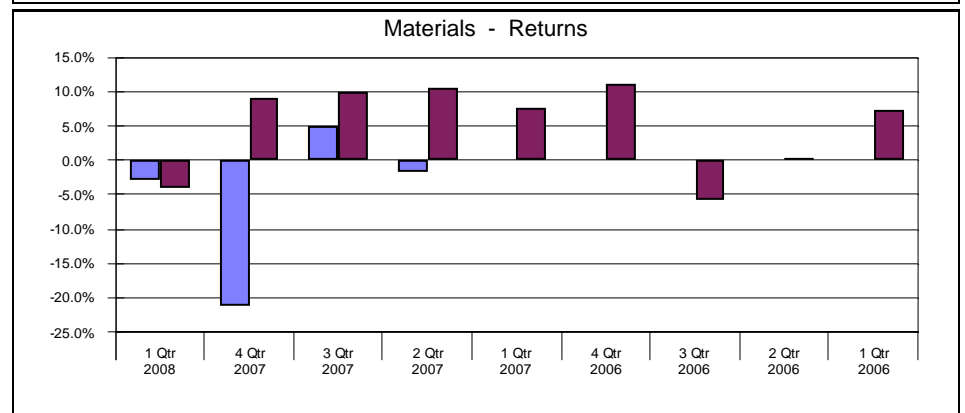
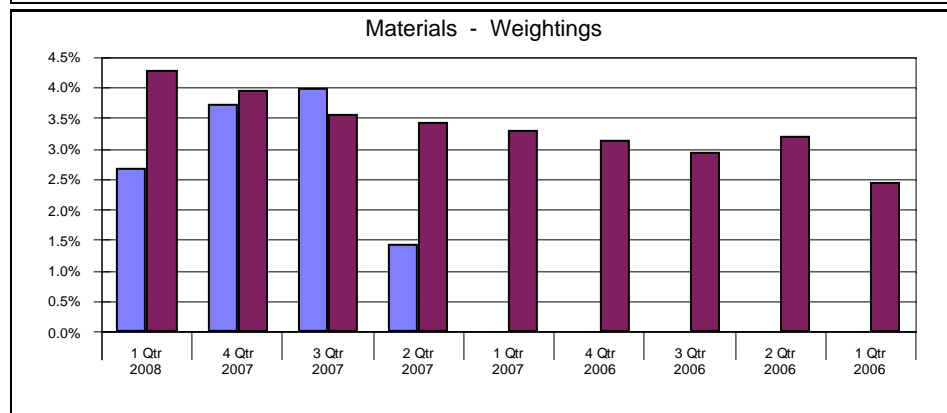
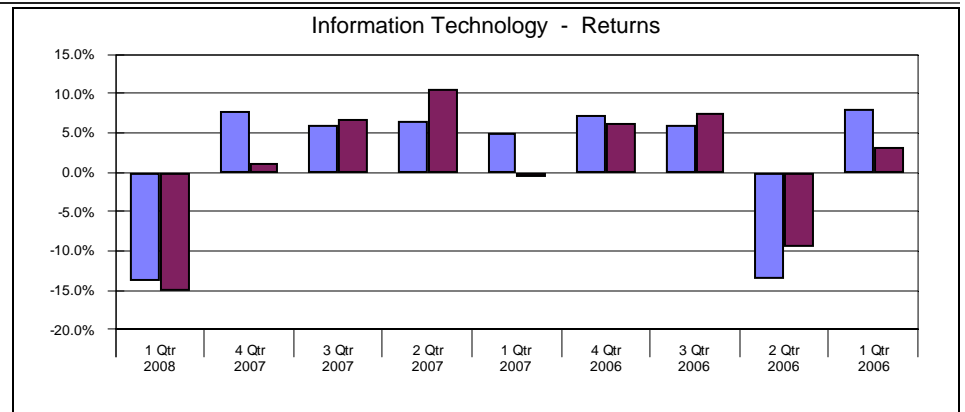
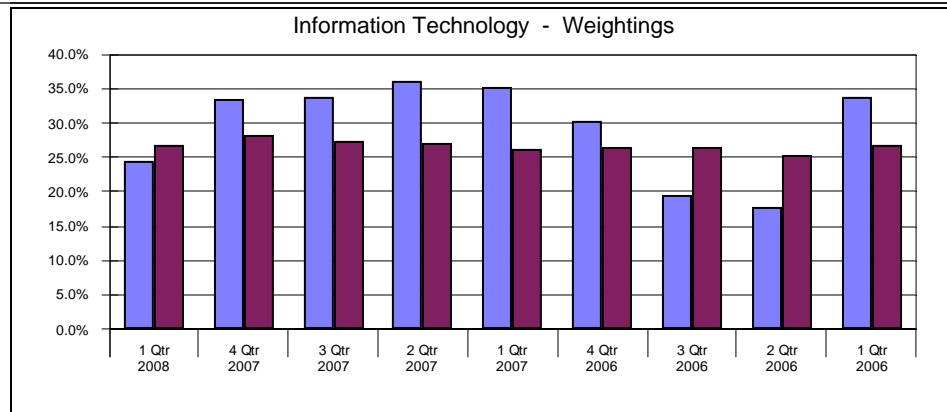

TCW CORE

RUSSELL 1000 GROWTH

Fresno County Employees' Retirement Association

Equity Only Sector Analysis Quarterly

Period Ending: March 31, 2008

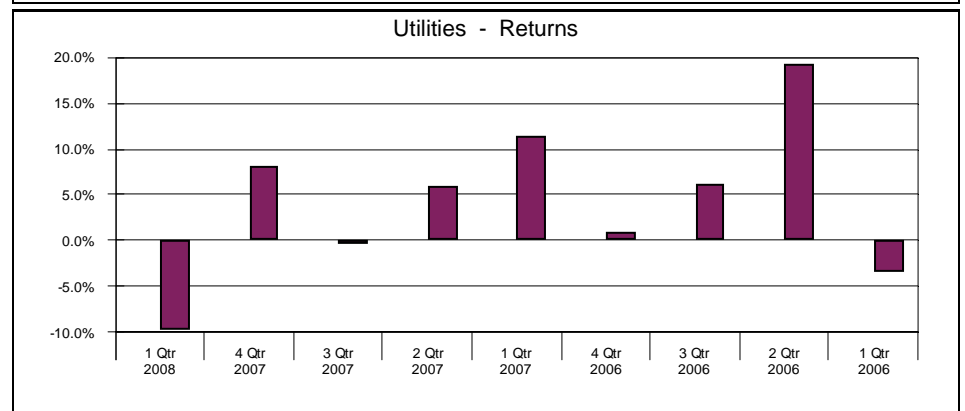
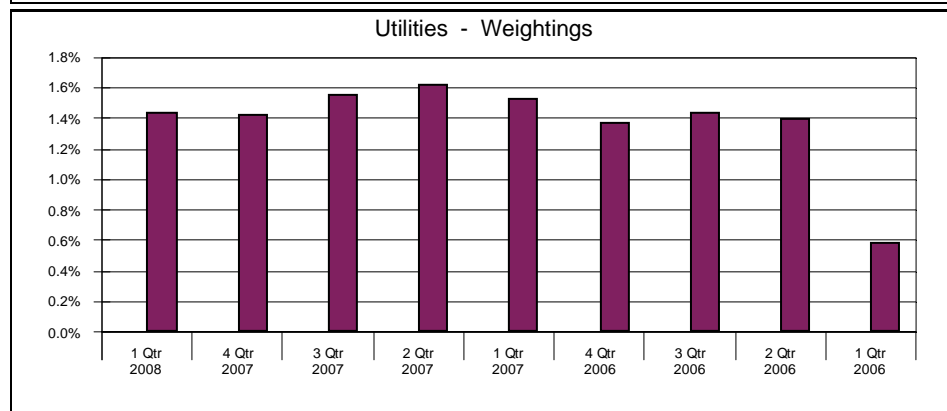
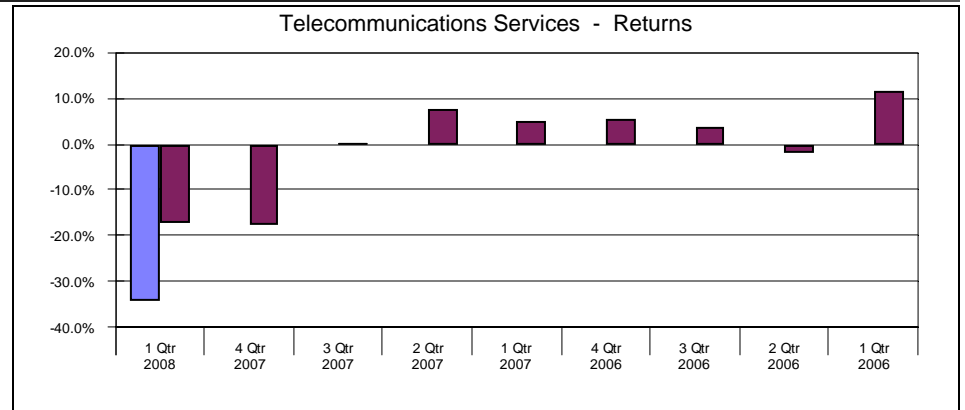
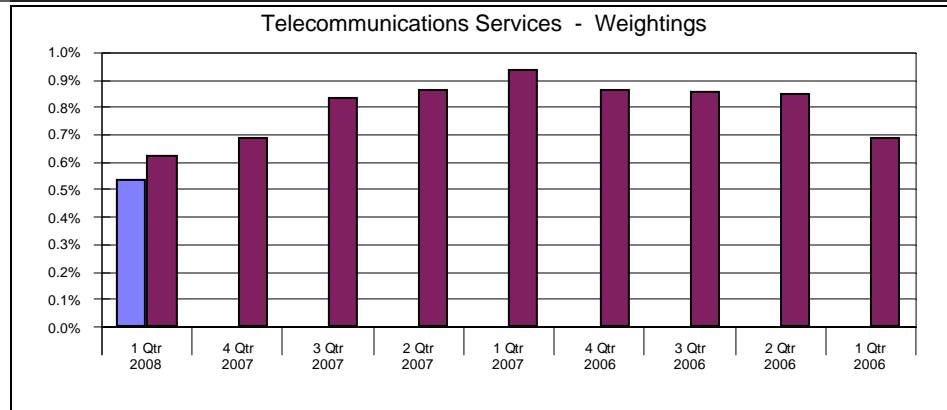

TCW CORE

RUSSELL 1000 GROWTH

Fresno County Employees' Retirement Association

Performance Attribution Geometric

Period Ending: March 31, 2008

TCW CORE

	Portfolio		RUSSELL 1000 GROWTH		Selection		Total
	Market Value	Return	Market Value	Return	Stock	Industry	
	A	B	C	D	E	F	
Consumer Discretionary	17.8	-16.2	10.9	-6.9	-1.9	0.3	-1.6
Consumer Staples	0.7	0.3	10.3	-1.4	0.0	-0.9	-0.9
Energy	7.2	-11.3	8.2	-6.6	-0.4	0.0	-0.4
Financials	11.8	-19.7	7.0	-15.8	-0.5	-0.3	-0.8
Health Care	17.0	-12.0	15.9	-12.2	0.0	0.0	0.0
Industrials	6.8	1.0	13.4	-7.9	0.7	-0.2	0.5
Information Technology	34.8	-17.1	28.3	-15.1	-0.8	-0.4	-1.2
Materials	3.9	-17.2	4.0	-3.9	-0.6	0.0	-0.6
Telecommunications Services	0.0	0.0	0.7	-17.2	0.0	0.1	0.1
Utilities	0.0	0.0	1.4	-9.7	0.0	0.0	0.0
	100.0	-14.6	100.0	-10.2	-3.5	-1.5	-4.9

Contribution

Stock	Industrials
	Health Care
Industry	Consumer Discretionary
	Telecommunications Services

Detractors

Stock	Consumer Discretionary
	Information Technology
Industry	Consumer Staples
	Information Technology

Fresno County Employees' Retirement Association

Portfolio Holdings And Characteristics - Equity

Period Ending: March 31, 2008

TCW CORE	Shares	Price	Portfolio Weight	Market Cap	Dividend Yield	Price / Earnings	Price / Book	Beta	Quarterly Return
Consumer Discretionary									
3M CO	9,200	79.15	0.8	56.01	2.5	14.1	4.8	0.71	-5.5
ACTIVISION INC NEW	23,000	27.31	0.7	8.03		30.0	5.5	1.31	-8.1
AMERICAN EAGLE OUTFITTERS INC	28,500	17.51	0.5	3.75	2.3	9.6	2.7	0.96	-15.2
COACH INC	15,000	30.15	0.5	10.61		16.4	5.9	1.54	-1.4
CORRECTIONS CORP AMER NEW	22,500	27.52	0.7	3.44		26.0	2.8	1.06	-6.7
COSTCO WHSL CORP NEW	9,800	64.97	0.7	28.15	0.9	24.5	3.3	0.77	-6.7
EBAY INC	28,800	29.84	0.9	39.63		119.4	3.4	1.87	-10.1
GENERAL ELEC CO	26,900	37.01	1.0	369.57	3.4	16.8	3.2	0.79	0.8
HARSCO CORP	9,100	55.38	0.5	4.68	1.4	18.4	3.0	1.35	-13.3
HOME DEPOT INC	24,300	27.97	0.7	47.20	3.2	12.3	2.2	1.01	4.7
HONEYWELL INTL INC	9,300	56.42	0.6	42.13	2.0	17.9	4.6	1.23	-7.9
IRON MTN INC PA	20,200	26.44	0.6	5.31		34.8	2.9	0.63	-28.6
JOHNSON CTLS INC	15,400	33.80	0.5	20.07	1.5	15.0	2.3	0.96	-5.8
KOHL'S CORP	11,300	42.89	0.5	13.25		12.7	2.2	0.77	-6.4
LAS VEGAS SANDS CORP	9,100	73.64	0.7	26.17			11.6	1.96	-28.5
MGM MIRAGE INC	25,600	58.77	1.6	17.27	0.3	12.5	2.8	1.80	-30.1
NEWS CORP	36,900	18.75	0.7	40.14	0.6	17.2	1.8	0.96	-8.2
O REILLY AUTOMOTIVE INC	20,100	28.52	0.6	3.29		17.1	2.1	1.17	-12.1
OFFICE DEPOT INC	46,100	11.05	0.5	3.02		7.7	1.0	1.22	-20.6
POLO RALPH LAUREN CORP	8,900	58.29	0.5	3.41	0.3	15.8	2.6	1.37	-5.6
ROSS STORES INC	19,900	29.96	0.6	4.06	1.3	15.8	4.6	0.86	17.6
SIRIUS SATELLITE RADIO INC	203,400	2.86	0.6	4.22				1.42	-5.6
TARGET CORP	17,600	50.68	0.9	41.20	1.1	15.2	2.7	0.96	1.6
TIFFANY + CO NEW	16,600	41.84	0.7	5.28	1.4	17.4	3.2	1.43	-8.7
TIME WARNER CABLE INC CL A	18,800	24.98	0.5	22.53		21.7			-9.5
WAL MART STORES INC	18,600	52.68	1.0	210.97	1.8	16.8	3.5	0.37	11.4
WYNN RESORTS LTD	6,500	100.64	0.7	11.37		43.0	5.9	1.95	-10.3
			19.0	49.84	1.6	23.5	3.6	1.19	-8.35

Fresno County Employees' Retirement Association

Portfolio Holdings And Characteristics - Equity

Period Ending: March 31, 2008

TCW CORE	Shares	Price	Portfolio Weight	Market Cap	Dividend Yield	Price / Earnings	Price / Book	Beta	Quarterly Return
Consumer Staples									
ALTRIA GROUP INC	12,000	22.20	0.3	46.80	4.2	15.6	8.2	1.03	-3.7
BROWN FORMAN CORP CLASS B	7,700	66.22	0.5	4.42	2.1	20.1	5.2	0.73	-10.2
CARDINAL HEALTH INC	10,900	52.51	0.6	18.72	0.9	39.8	2.6	0.63	-8.9
COCA COLA CO	14,800	60.87	0.9	141.46	2.5	23.7	6.5	0.67	-0.2
CVS CAREMARK CORP	12,900	40.51	0.6	58.01	0.6	21.1	1.9	0.98	2.1
LOEWS CORP CAROLINA GROUP STK	8,600	72.55	0.7	7.87	2.5	9.2	11.5	1.10	-14.4
MCDONALDS CORP	8,600	55.77	0.5	64.23	2.7	28.9	4.3	1.52	-4.7
PEPSICO INC	24,600	72.20	1.9	115.65	2.1	21.2	6.7	0.58	-4.4
PROCTER AND GAMBLE CO	15,600	70.07	1.2	215.64	2.0	21.2	3.3	0.76	-4.1
SYSCO CORP	18,800	29.02	0.6	17.52	3.0	17.1	5.4	1.11	-6.3
WALGREEN CO	21,800	38.09	0.9	37.76	1.0	18.1	3.4	0.50	0.3
YUM BRANDS INC	13,900	37.21	0.5	17.69	1.6	22.1		1.12	-2.4
PHILIP MORRIS INTL ORD SHR	12,000	50.58	0.6	106.64					
			9.7	83.81	2.0	21.5	5.4	0.81	-4.14
Energy									
BAKER HUGHES INC	8,800	68.50	0.6	21.19	0.8	14.5	3.4	1.17	-15.4
CAMERON INTL CORP	14,100	41.64	0.6	9.09		19.3	4.3	0.84	-13.5
EXXON MOBIL CORP	14,200	84.58	1.3	452.51	1.7	11.6	3.7	0.90	-9.3
GRANT PRIDECO INC	11,000	49.22	0.6	6.16		12.3	3.6	1.02	-11.3
HALLIBURTON CO	14,000	39.33	0.6	34.62	0.9	10.7	6.1	1.20	4.0
NATIONAL OILWELL VARCO INC	10,100	58.38	0.6	20.84		15.5	3.1	1.15	-20.5
PRIDE INTERNATIONAL INC	14,100	34.95	0.5	5.84		14.2	1.7	1.11	3.1
SCHLUMBERGER LTD	16,400	87.00	1.5	104.20	1.0	20.7	7.0	1.26	-11.3
SOUTHWESTERN ENERGY CO	21,400	33.69	0.8	11.52	0.1	53.1	7.0	1.18	20.9
SUNOCO INC	9,700	52.47	0.5	6.17	2.3	7.1	2.4	1.26	-27.2
TRANSOCEAN INC SHS NEW	4,300	135.20	0.6	42.96		9.6	3.4	1.11	-5.6
VALERO ENERGY CORP	11,300	49.11	0.6	26.26	1.0	6.4	1.4	0.99	-29.7
XTO ENERGY INC	13,800	61.86	0.9	29.91	0.8	17.5	3.8	0.90	20.7
			9.7	89.49	1.1	17.2	4.3	1.08	-6.51

Fresno County Employees' Retirement Association

Portfolio Holdings And Characteristics - Equity

Period Ending: March 31, 2008

TCW CORE	Shares	Price	Portfolio Weight	Market Cap	Dividend Yield	Price / Earnings	Price / Book	Beta	Quarterly Return
Financials									
AMERICAN EXPRESS CO	21,000	43.72	1.0	50.54	1.6	13.0	4.6	1.23	-15.7
BANK NEW YORK MELLON CORP	12,200	41.73	0.5	47.63	2.3	17.5	1.6	1.09	-14.0
BLACKROCK INC	2,300	204.18	0.5	23.95	1.5	27.1	2.0	1.08	-5.5
BROADRIDGE FINL SOLUTIONS INC	28,500	17.60	0.5	2.46	1.4	11.9	4.6		-21.3
COVANTA HLDG CORP	19,700	27.50	0.6	4.23		32.4	4.1	1.51	-0.6
DUKE RLTY CORP	20,100	22.81	0.5	3.34	8.4	33.1	1.7	0.90	-10.7
GENERAL GROWTH PPTYS INC	14,100	38.17	0.6	9.31	5.2	32.3	6.4	1.40	-5.9
GLOBAL PMTS INC	14,000	41.36	0.6	3.29	0.2	22.5	3.5	1.00	-11.1
GOLDMAN SACHS GROUP INC	4,200	165.39	0.7	65.48	0.8	7.8	1.6	1.60	-23.0
INTERCONTINENTALEXCHANGE INC	2,100	130.50	0.3	9.15		38.5	6.2		-32.2
INVESTMENT TECHNOLOGY GROUP	11,000	46.18	0.5	2.02		18.6	2.9	1.20	-3.0
PRUDENTIAL FINL INC	8,200	78.25	0.7	34.74	1.5	10.3	1.5	1.36	-15.9
STATE STREET CORPORATION	5,700	79.00	0.5	30.61	1.2	22.9	2.7	0.97	-2.4
UDR INC	24,600	24.52	0.6	3.27	5.4		3.9	0.77	25.7
			8.1	23.54	2.5	20.5	3.3	1.19	-9.31
Health Care									
ABBOTT LABS	13,700	55.15	0.8	85.25	2.6	23.9	4.8	0.46	-1.3
AETNA INC	15,400	42.09	0.7	20.90	0.1	12.1	2.1	1.31	-27.1
BARR PHARMACEUTICALS INC	11,200	48.31	0.6	5.21		36.9	2.8	0.92	-9.0
BECKMAN COULTER INC	8,400	64.55	0.6	4.05	1.1	19.7	2.8	0.84	-11.1
BRISTOL MYERS SQUIBB CO	27,700	21.30	0.6	42.16	5.8	19.5	4.0	0.98	-18.7
CELGENE CORP	11,700	61.29	0.8	24.75		113.5	8.7	0.87	32.6
CEPHALON INC	11,100	64.40	0.8	4.36			3.3	0.93	-10.3
COVANCE INC	6,600	82.97	0.6	5.32		30.6	4.8	0.45	-4.2
DENTSPLY INTL INC NEW	16,100	38.60	0.7	5.83	0.5	23.0	3.8	0.73	-14.2
GENENTECH INC	7,700	81.18	0.7	85.49		31.3	7.2	1.21	21.0
GENZYME CORP COM GEN DIV	7,500	74.54	0.6	19.95		42.8	3.0	0.88	0.1
GILEAD SCIENCES INC	15,000	51.53	0.8	47.86		30.7	13.9	1.07	12.0
IDEXX LABS INC	11,000	49.26	0.6	3.00		33.7	6.9	0.55	-16.0
JOHNSON + JOHNSON	13,900	64.87	0.9	183.75	2.6	17.9	4.3	0.29	-2.1
LILLY ELI + CO	12,300	51.59	0.7	58.66	3.6	19.0	4.3	0.70	-2.5
MEDCO HEALTH SOLUTIONS INC	12,000	43.79	0.6	22.94		26.9	3.4	0.86	-13.6
MEDTRONIC INC	14,600	48.37	0.7	54.32	1.0	24.9	5.0	0.42	-3.5
MERCK + CO INC	14,300	37.95	0.6	82.17	4.0	25.5	4.5	0.70	-34.1
SCHEIN HENRY INC	10,700	57.40	0.6	5.14		22.2	2.9	0.93	-6.5
SCHERING PLOUGH CORP	26,100	14.41	0.4	23.36	1.8		3.0	0.98	-45.7
UNITEDHEALTH GROUP INC	18,500	34.36	0.7	43.00	0.1	10.0	2.2	0.76	-40.9
VARIAN MED SYS INC	14,200	46.84	0.7	5.89		24.8	7.1	0.98	-10.2
VERTEX PHARMACEUTICALS INC	30,700	23.89	0.8	3.18			11.7	1.50	2.8
WYETH	17,100	41.76	0.8	55.87	2.7	12.4	3.1	0.56	-4.8
			16.0	40.84	2.2	28.7	5.2	0.82	-7.14

Fresno County Employees' Retirement Association

Portfolio Holdings And Characteristics - Equity

Period Ending: March 31, 2008

TCW CORE	Shares	Price	Portfolio Weight	Market Cap	Dividend Yield	Price / Earnings	Price / Book	Beta	Quarterly Return
Industrials									
ALLIANT TECHSYSTEMS INC	4,700	103.53	0.5	3.40		16.8	6.1	0.67	-9.0
BE AEROSPACE INC	17,600	34.95	0.6	3.25		21.1	2.6	1.60	-33.9
BOEING CO	14,800	74.37	1.2	56.88	2.2	14.1	6.3	1.22	-14.5
C H ROBINSON WORLDWIDE INC	3,400	54.40	0.2	9.32	1.6	29.2	8.9	1.26	0.9
EMERSON ELEC CO	10,300	51.46	0.6	40.44	2.3	18.6	4.6	1.09	-8.7
EXPEDITORS INTL WA INC	700	45.18	0.0	9.63	0.6	37.3	7.8	0.83	1.1
FEDEX CORP	7,000	92.67	0.7	28.73	0.4	14.6	2.3	0.78	4.0
GARMIN LTD	7,600	54.01	0.4	11.72	1.4	13.9	5.0	1.54	-44.3
L 3 COMMUNICATIONS HLDG CORP	4,800	109.34	0.6	13.38	1.1	18.3	2.3	0.83	3.5
LOCKHEED MARTIN CORP	7,800	99.30	0.8	40.53	1.7	14.0	4.1	0.44	-5.3
UNION PAC CORP	4,300	125.38	0.6	32.69	1.4	18.1	2.1	0.95	0.2
UNITED PARCEL SVC INC CL B	13,400	73.02	1.0	50.55	2.5		6.2	0.79	3.9
UNITED TECHNOLOGIES CORP	8,400	68.82	0.6	67.55	1.9	16.1	3.2	1.03	-9.7
			7.8	34.81	1.7	16.8	4.4	0.98	-8.80
Information Technology									
APPLE INC COM NPV	7,600	143.50	1.1	126.12	0.1	31.5	8.6	1.72	-27.6
AUTODESK INCORPORATED COM STK NPV	5,600	31.48	0.2	7.25		21.4	6.5	1.53	-36.7
BEA SYS INC	29,500	19.15	0.6	7.93		38.3	5.6	1.09	21.4
CERNER CORP	14,600	37.28	0.6	3.00		24.4	2.6	1.02	-33.9
CIENA CORP	17,000	30.83	0.6	2.68		30.2	3.1	1.48	-9.6
CISCO SYS INC	95,200	24.09	2.4	143.60		18.7	4.7	1.31	-11.0
COGNIZANT TECHNOLOGY SOLUTIONS	18,500	28.83	0.6	8.31		25.1	5.7	1.29	-15.1
CROWN CASTLE INTL CORP	14,200	34.49	0.5	9.71			3.1	1.56	-17.1
CYPRESS SEMICONDUCTOR CORP	26,200	23.61	0.7	3.61		10.3	2.2	1.98	-34.5
DELL INC	28,200	19.92	0.6	44.64		15.2	10.2	1.34	-18.7
EMC CORP	49,100	14.34	0.7	30.12		18.6	2.4	1.65	-22.6
FIRST SOLAR INC	2,600	231.14	0.6	18.18		113.9			-13.5
GOOGLE INC	3,400	440.47	1.6	104.28		33.1	6.1	1.39	-36.3
HEWLETT PACKARD CO	42,400	45.66	2.0	112.57	0.7	15.6	3.1	1.32	-9.4
INTEL CORP	66,100	21.18	1.5	122.59	2.6	17.9	2.9	1.56	-20.1
INTERNATIONAL BUSINESS MACHS	11,200	115.14	1.4	159.39	1.4	16.0	5.6	0.95	6.9
MICROSOFT CORP	123,100	28.38	3.7	264.13	1.6	16.1	8.6	0.89	-20.0
NETAPP INC	29,700	20.05	0.6	6.89		24.2	3.7	1.56	-19.7
ORACLE CORP	67,900	19.56	1.4	100.47		20.0	5.9	1.23	-13.4
QUALCOMM INC	33,300	41.00	1.4	66.10	1.4	20.2	4.3	1.20	4.5
RED HAT INC	31,000	18.39	0.6	3.58		51.1	4.3	1.41	-11.8
SALESFORCE COM INC	12,700	57.87	0.8	6.83			15.3	1.74	-7.7
TEXAS INSTRS INC	16,800	28.27	0.5	37.50	1.4	15.4	3.8	1.72	-15.1
TRIMBLE NAVIGATION LTD	21,700	28.59	0.7	3.46		30.4	3.1	1.62	-5.5
VERISIGN INC	10,200	33.24	0.4	7.09			4.8	1.90	-11.6
YAHOO INC	18,300	28.93	0.6	38.68		61.6	4.0	1.10	24.4
			26.2	100.34	1.3	24.9	5.5	1.33	-13.83
Wurts & Associates					Performance Measurement System				

Fresno County Employees' Retirement Association

Portfolio Holdings And Characteristics - Equity

Period Ending: March 31, 2008

Materials									
AIRGAS INC	12,600	45.47	0.6	3.75	1.1	18.6	3.2	1.25	-12.5
ALLEGHENY TECHNOLOGIES INC	2,300	71.36	0.2	7.30	1.0	9.8	3.3	2.08	-17.2
MONSANTO CO NEW	8,400	111.50	1.0	61.10	0.6	57.2	8.1	1.29	0.0
PRAXAIR INC	7,100	84.23	0.6	26.39	1.8	23.3	5.2	0.91	-4.6
STEEL DYNAMICS INC	14,200	33.04	0.5	6.23	0.6	16.4	4.1	1.76	11.1
			2.9	28.92	1.0	31.9	5.5	1.33	-2.76
Telecommunications Services									
NII HLDGS INC CL B NEW	17,400	31.78	0.6	5.40		15.1	2.5	1.90	-34.2
			0.6	5.40		15.1	2.5	1.90	-34.23
TCW CORE			100.0	64.62	1.7	23.3	4.7	1.11	-9.11

Fresno County Employees' Retirement Association

Equity Activity

Period Ending: March 31, 2008

Start from Dec 31, 2007 **TCW CORE**

Additions				Deletions			
Security Name	Shares	Market Value	New	Security Name	Shares	Market Value	Eliminated
APPLE INC COM NPV	16,700	2,151,215	*	ALLEGHENY TECHNOLOGIES INC	28,200	1,925,709	
BERKSHIRE HATHAWAY INC DEL	11	1,452,804	*	AMERICAN INTL GROUP INC	17,200	782,342	*
C H ROBINSON WORLDWIDE INC	4,320	224,452	*	AUTODESK INCORPORATED COM STK NPV	92,180	3,115,839	
CERNER CORP	23,600	1,052,536	*	C H ROBINSON WORLDWIDE INC	11,100	608,239	
GILEAD SCIENCES INC	70,500	3,145,927	*	DELL INC	67,800	1,348,349	
GOOGLE INC	2,500	1,110,050	*	EXPEDITORS INTL WA INC	18,300	751,688	
INTERCONTINENTALEXCHANGE INC	7,900	1,058,590	*	NETWORK APPLIANCE INC	12,900	300,259	*
N/A		343	*	PROGRESSIVE CORP OHIO	25,305	412,263	*
RESEARCH IN MOTION LTD	23,300	2,175,600	*	QUALCOMM INC	80,700	3,045,588	
SCHERING PLOUGH CORP	51,800	1,249,198	*	SALESFORCE COM INC	55,100	3,112,837	
VISA INC COM CL A	15,900	699,600	*	WALGREEN CO	22,100	796,041	
YUM BRANDS INC	35,920	1,286,850	*	WELLPOINT INC	31,900	1,503,539	*