

COUNTY OF FRESNO
REQUEST FOR QUOTATION
NUMBER: 760-5434
PETERBILT DUMP TRUCKS

Issue Date: February 1, 2016

Closing Date: FEBRUARY 24, 2016

Quotation will be considered LATE when the official Purchasing time clock reads 2:00 P.M.

Questions regarding this RFQ should be directed to: Debbie Scharnick,
e-mail countypurchasing@co.fresno.ca.us or phone (559) 600-7111.

Check County of Fresno Purchasing's website at
<https://www2.co.fresno.ca.us/0440/Bids/BidsHome.aspx>
for any future addenda.

Please submit all Quotations to:

County of Fresno – Purchasing
4525 E. Hamilton Avenue, 2nd Floor
Fresno, CA 93702-4599

BIDDER TO COMPLETE

Undersigned agrees to furnish the commodity or service stipulated in the attached response at the prices and terms stated, subject to the attached "County of Fresno Purchasing Standard Instructions And Conditions For Requests For Proposals (RFP's) And Requests For Quotations (RFQ's)".

Except as noted on individual items, the following will apply to all items in the Quotation Schedule:

- A cash discount of _____ % _____ days will apply.

COMPANY

ADDRESS

CITY

STATE

ZIP CODE

()

TELEPHONE NUMBER

()

FACSIMILE NUMBER

E-MAIL ADDRESS

SIGNATURE (IN BLUE INK)

PRINT NAME

TITLE

Purchasing Use: DLS:ssj

ORG/Requisition: 8911 / 8911620033

COUNTY OF FRESNO PURCHASING
STANDARD INSTRUCTIONS AND CONDITIONS FOR
REQUESTS FOR PROPOSALS (RFP'S) AND REQUESTS FOR QUOTATIONS (RFQ'S)

Note: the reference to "bids" in the following paragraphs applies to RFP's and RFQ's

GENERAL CONDITIONS

By submitting a bid the bidder agrees to the following conditions. These conditions will apply to all subsequent purchases based on this bid.

1. BID PREPARATION:

- A) All prices and notations must be typed or written in ink. No erasures permitted. Errors may be crossed out, initialed and corrections printed in ink by person signing bid.
- B) Brand Names: Brand names and numbers when given are for reference. Equal items will be considered, provided the offer clearly describes the article and how it differs from that specified. In the absence of such information it shall be understood the offering is exactly as specified.
- C) State brand or make of each item. If bidding on other than specified, state make, model and brand being bid and attach supporting literature/specifications to the bid.
- D) Bid on each item separately. Prices should be stated in units specified herein. All applicable charges must be quoted; charges on invoice not quoted herein will be disallowed.
- E) Time of delivery is a part of the consideration and must be stated in definite terms and must be adhered to. F.O.B. Point shall be destination or freight charges must be stated.
- F) All bids must be dated and signed with the firm's name and by an authorized officer or employee.
- G) Unless otherwise noted, prices shall be firm for one hundred eighty (180) days after closing date of bid.

2. SUBMITTING BIDS:

- A) Each bid must be submitted on forms provided in a sealed envelope/package with bid number and closing date and time on the outside of the envelope/package.
- B) Interpretation: Should any discrepancies or omissions be found in the bid specifications or doubt as to their meaning, the bidder shall notify the Buyer in writing at once. The County shall not be held responsible for verbal interpretations. Questions regarding the bid must be received by Purchasing stated within this document. All addenda issued shall be in writing, duly issued by Purchasing and incorporated into the contract.
- C) ISSUING AGENT/AUTHORIZED CONTACT: This RFP/RFQ has been issued by County of Fresno, Purchasing. Purchasing shall be the vendor's sole point of contact with regard to the RFP/RFQ, its content, and all issues concerning it.

All communication regarding this RFP/RFQ shall be directed to an authorized representative of County Purchasing. The specific buyer managing this RFP/RFQ is identified on the cover page, along with his or her telephone number, and he or she should be the primary point of contact for discussions or information pertaining to the RFP/RFQ.

Contact with any other County representative, including elected officials, for the purpose of discussing this RFP/RFQ, its content, or any other issue concerning it, is prohibited unless authorized by Purchasing. Violation of this clause, by the vendor having unauthorized contact (verbally or in writing) with such other County representatives, may constitute grounds for rejection by Purchasing of the vendor's quotation.

The above stated restriction on vendor contact with County representatives shall apply until the County has awarded a purchase order or contract to a vendor or vendors, except as follows. First, in the event that a vendor initiates a formal protest against the RFP/RFQ, such vendor may contact the appropriate individual, or individuals who are managing that protest as outlined in the County's established protest procedures. All such contact must be in accordance with the sequence set forth under the protest procedures. Second, in the event a public hearing is scheduled before the Board of Supervisors to hear testimony prior to its approval of a purchase order or contract, any vendor may address the Board.

- D) Bids received after the closing time will NOT be considered.
- E) Bidders are to bid what is specified or requested first. If unable to or unwilling to, bidder may bid alternative or option, indicating all advantages, disadvantages and their associated cost.

3. FAILURE TO BID:

- A) If not bidding, return bid sheet and state reason for no bid or your name may be removed from mailing list.

4. TAXES, CHARGES AND EXTRAS:

- A) County of Fresno is subject to California sales and/or use tax (8.225%). Please indicate as a separate line item if applicable.
- B) **DO NOT** include Federal Excise Tax. County is exempt under Registration No. 94-73-03401-K.
- C) County is exempt from Federal Transportation Tax. Exemption certificate is not required where shipping papers show consignee as County of Fresno.
- D) Charges for transportation, containers, packing, etc. will not be paid unless specified in bid.

5. W-9 – REQUEST FOR TAXPAYER IDENTIFICATION NUMBER AND CERTIFICATION & CALIFORNIA FORM 590 WITHHOLDING EXEMPTION CERTIFICATE:

Upon award of bid, the vendor shall submit to County Purchasing, a completed IRS Form W-9 - Request for Taxpayer Identification Number and Certification and a California Form 590 Withholding Exemption Certificate if not currently a County of Fresno approved vendor.

Quotation No. 760-5434

6. AWARDS:

- A) Award(s) will be made to the most responsive responsible bidder; however, the Fresno County Local Vendor Preference and/or the Disabled Veteran Business Enterprise Preference shall take precedence when applicable. Said Preferences apply only to Request for Quotations for materials, equipment and/or supplies only (no services); the preference do not apply to Request for Proposals. RFQ evaluations will include such things as life-cycle cost, availability, delivery costs and whose product and/or service is deemed to be in the best interest of the County. The County shall be the sole judge in making such determination.
- B) Unless bidder gives notice of all-or-none award in bid, County may accept any item, group of items or on the basis of total bid.
- C) The County reserves the right to reject any and all bids and to waive informalities or irregularities in bids.
- D) Award Notices are tentative: Acceptance of an offer made in response to this RFP/RFQ shall occur only upon execution of an agreement by both parties or issuance of a valid written Purchase Order by Fresno County Purchasing.
- E) After award, all bids shall be open to public inspection. The County assumes no responsibility for the confidentiality of information offered in a bid.

7. TIE BIDS:

All other factors being equal, the contract shall be awarded to the Fresno County vendor or, if neither or both are Fresno County vendors, it may be awarded by the flip of a coin in the presence of witnesses or the entire bid may be rejected and re-bid. If the General Requirements of the RFQ state that they are applicable, the provisions of the Fresno County Local Vendor Preference shall take priority over this paragraph.

8. PATENT INDEMNITY:

The vendor shall hold the County, its officers, agents and employees, harmless from liability of any nature or kind, including costs and expenses, for infringement or use of any copyrighted or un-copyrighted composition, secret process, patented or unpatented invention, article or appliance furnished or used in connection with this bid.

9. SAMPLES:

Samples, when required, must be furnished and delivered free and, if not destroyed by tests, will upon written request (within thirty (30) days of bid closing date) be returned at the bidder's expense. In the absence of such notification, County shall have the right to dispose of the samples in whatever manner it deems appropriate.

10. RIGHTS AND REMEDIES OF COUNTY FOR DEFAULT:

- A) In case of default by vendor, the County may procure the articles or service from another source and may recover the cost difference and related expenses occasioned thereby from any unpaid balance due the vendor or by proceeding against performance bond of the vendor, if any, or by suit against the vendor. The prices paid by the County shall be considered the prevailing market price at the time such purchase is made.
- B) Articles or services, which upon delivery inspection do not meet specifications, will be rejected and the vendor will be considered in default. Vendor shall reimburse County for expenses related to delivery of non-specified goods or services.
- C) Regardless of F.O.B. point, vendor agrees to bear all risks of loss, injury or destruction to goods and materials ordered herein which occur

prior to delivery and such loss, injury or destruction shall not release vendor from any obligation hereunder.

11. DISCOUNTS:

Terms of less than fifteen (15) days for cash payment will be considered as net in evaluating this bid. A discount for payment within fifteen (15) days or more will be considered in determining the award of bid. Discount period will commence either the later of delivery or receipt of invoice by the County. Standard terms are Net forty-five (45) days.

12. SPECIAL CONDITIONS IN BID SCHEDULE SUPERSEDE GENERAL CONDITIONS:

The "General Conditions" provisions of this RFP/RFQ shall be superseded if in conflict with any other section of this bid, to the extent of any such conflict.

13. SPECIAL REQUIREMENT:

With the invoice or within twenty-five (25) days of delivery, the seller must provide to the County a Material Safety Data Sheet for each product, which contains any substance on "The List of 800 Hazardous Substances", published by the State Director of Industrial Relations. (See Hazardous Substances Information and Training Act, California State Labor Code Sections 6360 through 6399.7.)

14. RECYCLED PRODUCTS/MATERIALS:

Vendors are encouraged to provide and quote (with documentation) recycled or recyclable products/materials which meet stated specifications.

15. YEAR COMPLIANCE WARRANTY:

Vendor warrants that any product furnished pursuant to this Agreement/order shall support a four-digit year format and be able to accurately process date and time data from, into and between the twentieth and twenty-first centuries, as well as leap year calculations. "Product" shall include, without limitation, any piece or component of equipment, hardware, firmware, middleware, custom or commercial software, or internal components or subroutines therein. This warranty shall survive termination or expiration of this Agreement.

In the event of any decrease in product functionality or accuracy related to time and/or date data related codes and/or internal subroutines that impede the product from operating correctly using dates beyond December 31, 1999, vendor shall restore or repair the product to the same level of functionality as warranted herein, so as to minimize interruption to County's ongoing business process, time being of the essence. In the event that such warranty compliance requires the acquisition of additional programs, the expense for any such associated or additional acquisitions, which may be required, including, without limitation, data conversion tools, shall be borne exclusively by vendor. Nothing in this warranty shall be construed to limit any rights or remedies the County may otherwise have under this Agreement with respect to defects other than year performance.

16. PARTICIPATION:

Bidder may agree to extend the terms of the resulting contract to other political subdivision, municipalities and tax-supported agencies.

Such participating Governmental bodies shall make purchases in their own name, make payment directly to bidder, and be liable directly to the bidder, holding the County of Fresno harmless.

17. CONFIDENTIALITY:

All services performed by vendor shall be in strict conformance with all applicable Federal, State of California and/or local laws and regulations relating to confidentiality, including but not limited to, California Civil Code,

Quotation No. 760-5434

California Welfare and Institutions Code, Health and Safety Code, California Code of Regulations, Code of Federal Regulations.

Vendor shall submit to County's monitoring of said compliance.

Vendor may be a business associate of County, as that term is defined in the "Privacy Rule" enacted by the Health Insurance Portability and Accountability Act of 1996 (HIPAA). As a HIPAA Business Associate, vendor may use or disclose protected health information ("PHI") to perform functions, activities or services for or on behalf of County as specified by the County, provided that such use or disclosure shall not violate HIPAA and its implementing regulations. The uses and disclosures if PHI may not be more expansive than those applicable to County, as the "Covered Entity" under HIPAA's Privacy Rule, except as authorized for management, administrative or legal responsibilities of the Business Associate.

Vendor shall not use or further disclose PHI other than as permitted or required by the County, or as required by law without written notice to the County.

Vendor shall ensure that any agent, including any subcontractor, to which vendor provides PHI received from, or created or received by the vendor on behalf of County, shall comply with the same restrictions and conditions with respect to such information.

18. APPEALS:

Appeals must be submitted in writing within seven (7) working days after notification of proposed recommendations for award. A "Notice of Award" is not an indication of County's acceptance of an offer made in response to this RFP/RFQ. Appeals should be submitted to County of Fresno Purchasing, 4525 E. Hamilton Avenue, Fresno, California 93702-4599 **and** in Word format to gcornuelle@co.fresno.ca.us. Appeals should address only areas regarding RFP/RFQ contradictions, procurement errors, quotation rating discrepancies, legality of procurement context, conflict of interest, and inappropriate or unfair competitive procurement grievance regarding the RFP/RFQ process.

Purchasing will provide a written response to the complainant within seven (7) working days unless the complainant is notified more time is required.

If the protesting bidder is not satisfied with the decision of Purchasing, he/she shall have the right to appeal to the Purchasing Agent/CAO within seven (7) working days after Purchasing's notification; except if, notified to appeal directly to the Board of Supervisors at the scheduled date and time.

If the protesting bidder is not satisfied with Purchasing Agent/CAO's decision, the final appeal is with the Board of Supervisors.

19. OBLIGATIONS OF CONTRACTOR:

A) CONTRACTOR shall perform as required by the ensuing contract. CONTRACTOR also warrants on behalf of itself and all subcontractors engaged for the performance of the ensuing contract that only persons authorized to work in the United States pursuant to the Immigration Reform and Control Act of 1986 and other applicable laws shall be employed in the performance of the work hereunder.

B) CONTRACTOR shall obey all Federal, State, local and special district laws, ordinances and regulations.

20. AUDITS & RETENTION:

The Contractor shall maintain in good and legible condition all books, documents, papers, data files and other records related to its performance under this contract. Such records shall be complete and available to Fresno County, the State of California, the federal government or their duly authorized representatives for the purpose of audit, examination, or copying during the term of the contract and for a period of at least three (3) years

following the County's final payment under the contract or until conclusion of any pending matter (e.g., litigation or audit), whichever is later. Such records must be retained in the manner described above until all pending matters are closed.

21. DISCLOSURE – CRIMINAL HISTORY & CIVIL ACTIONS:

Applies to Request for Proposal (RFP); does not apply to Request for Quotation (RFQ) unless specifically stated elsewhere in the RFQ document.

In their proposal, the bidder is required to disclose if any of the following conditions apply to them, their owners, officers, corporate managers and partners (hereinafter collectively referred to as "Bidder"):

- Within the three-year period preceding the proposal, they have been convicted of, or had a civil judgment rendered against them for:
 - fraud or a criminal offense in connection with obtaining, attempting to obtain, or performing a public (federal, state, or local) transaction or contract under a public transaction;
 - violation of a federal or state antitrust statute;
 - embezzlement, theft, forgery, bribery, falsification, or destruction of records; or
 - false statements or receipt of stolen property

Within a three-year period preceding their proposal, they have had a public transaction (federal, state, or local) terminated for cause or default.

22. DATA SECURITY:

Individuals and/or agencies that enter into a contractual relationship with the COUNTY for the purpose of providing services must employ adequate controls and data security measures, both internally and externally to ensure and protect the confidential information and/or data provided to contractor by the COUNTY, preventing the potential loss, misappropriation or inadvertent access, viewing, use or disclosure of COUNTY data including sensitive or personal client information; abuse of COUNTY resources; and/or disruption to COUNTY operations.

Individuals and/or agencies may not connect to or use COUNTY networks/systems via personally owned mobile, wireless or handheld devices unless authorized by COUNTY for telecommuting purposes and provide a secure connection; up to date virus protection and mobile devices must have the remote wipe feature enabled. Computers or computer peripherals including mobile storage devices may not be used (COUNTY or Contractor device) or brought in for use into the COUNTY's system(s) without prior authorization from COUNTY's Chief Information Officer and/or designee(s).

No storage of COUNTY's private, confidential or sensitive data on any hard-disk drive, portable storage device or remote storage installation unless encrypted according to advance encryption standards (AES of 128 bit or higher).

The COUNTY will immediately be notified of any violations, breaches or potential breaches of security related to COUNTY's confidential information, data and/or data processing equipment which stores or processes COUNTY data, internally or externally.

COUNTY shall provide oversight to Contractor's response to all incidents arising from a possible breach of security related to COUNTY's confidential client information. Contractor will be responsible to issue any notification to affected individuals as required by law or as deemed necessary by COUNTY in its sole discretion. Contractor will be responsible for all costs incurred as a result of providing the required notification.

Quotation No. 760-5434

23. PURCHASING LOCATION & HOURS:

Fresno County Purchasing is located at 4525 E. Hamilton Avenue (**second floor**), Fresno, CA 93702. Non-holiday hours of operation are Monday through Friday, 8:00 A.M. to 12:00 Noon and 1:00 P.M. to 5:00 P.M. PST; Purchasing is closed daily from 12:00 Noon to 1:00 P.M. The following holiday office closure schedule is observed:

January 1*	New Year's Day
Third Monday in January	Martin Luther King, Jr.'s Birthday
Third Monday in February	Washington - Lincoln Day
March 31*	Cesar Chavez' Birthday
Last Monday in May	Memorial Day
July 4*	Independence Day
First Monday in September	Labor Day
November 11*	Veteran's Day
Fourth Thursday in November	Thanksgiving Day
Friday following Thanksgiving	
December 25*	Christmas

* When this date falls on a Saturday, the holiday is observed the preceding Friday. If the date falls on a Sunday, the holiday is observed the following Monday.

24. FRESNO COUNTY BOARD OF SUPERVISORS ADMINISTRATIVE POLICIES:

ADMINISTRATIVE POLICY NUMBER 5

Contract Salary Limitation Fresno

County Administrative Policy No. 5 provides that in contracts with non-profit organizations that primarily serve Fresno County and professional service contracts where Fresno County is the sole client, the contractors must agree to the following contract language: "The contractor agrees to limit administrative cost to a maximum of 15% of the total program budget and to limit employee benefits to a maximum of 20% of total salaries for those employees working under this agreement during the term of the agreement. Failure to conform to this provision will be grounds for contract termination at the option of the County of Fresno." Any bidder that wishes an exemption from this contract requirements must set forth the request for exemption, as well as a complete explanation of why the exemption should be granted, in the bidder's response to the RFP. Only the Board of Supervisors can approve such exemption.

Policy Statement: Contractors shall be limited to a maximum 15% administrative cost as compared to the total program budget and employee benefits shall be limited to a maximum of 20% of salaries.

The following language will be included in each applicable contract:

"The contractor agrees to limit administrative cost to a maximum of 15% of the total program budget and to limit employee benefits to a maximum of 20% of total salaries for those employees working under this agreement during the term of this agreement. Failure to conform to this provision will be grounds for contract termination at the option of the County of Fresno."

The above provision shall be applied to renewal or multi-year contracts with non-profit organizations which primarily serve Fresno County and

professional services contracts where

Fresno County is the sole client, such as:

- Community based organization service contracts related to social services, health services, or probation services.
- Cultural art program contracts.
- Professional services contracts.

This policy will not apply to contracts between the County and the Federal or State governments; or one-time contracts. The Board of Supervisors will consider exemptions to this policy only upon the recommendation of the County Administrative Office.

Management Responsibility: It shall be the responsibility of any County official authorized by the Board of Supervisors to execute contracts or enter into agreements on behalf of the County to review all applicable contracts to insure that this policy is fully enforced.

It shall be the responsibility of the County Administrative Officer to review requests for exemptions to this policy and to make recommendations to the Board of Supervisors on such requests for exemption.

ADMINISTRATIVE POLICY NUMBER 34

Competitive Bids and Requests for Proposals

Fresno County Administrative Policy No. 34 provides that no person, firm or subsidiary thereof who has been awarded a consulting services contract by the County, may submit a bid for, or be awarded a contract for, the provision of services, procurement of goods or supplies, or any other related action which is required, suggested, or otherwise deemed appropriate in the end product of the consulting services contract. Any bidder that wishes an exemption from this contract limitation must set forth the request for exemption, as well as a complete explanation of why the exemption should be granted, in the bidder's response to the RFP. Only the Board of Supervisors, on a four-fifths (4/5) vote finding that such waiver is in the best interests of the County, can waive this policy.

Definitions: Purchasing Authority and Responsibility – In accordance with the State of California Government Code Section 25500 et seq., and the Fresno County Ordinance Code Chapter 2.56, the Board of Supervisors has established a County Purchasing Agent. The Board has designated the County Administrative Officer as the Purchasing Agent. Unless otherwise restricted, all necessary authority and responsibility has been delegated to the Purchasing Agent to satisfy the acquisition requirements of the County. The Purchasing Agent may defer day-to-day acquisition management to the Purchasing Manager as appropriate.

Policy Statement: Competitive bids or requests for proposals shall be secured for all contracts for goods or services which are proposed to be acquired by the County except when in unusual or extraordinary circumstances, a department head, requests an exception to competitive bidding. All such requests must be documented by the department head including a detailed description of the facts justifying the exception. The request must receive concurrence of the procurement authority who will sign that particular contract i.e. the Board of Supervisors or Purchasing Agent/Purchasing Manager. The following circumstances are examples which constitute "Suspension of Competition":

- In an emergency when goods or services are immediately necessary for the preservation of the public health, welfare, or safety, or for the protection of County property.
- When the contract is with a federal, state, or local governmental agency.

Quotation No. 760-5434

- When the department head, with the concurrence of the Purchasing Agent, finds that the cost of preparing and administering a competitive bidding process in a particular case will equal or exceed the estimated contract amount or \$1,000 whichever is more.
- When a contract provides only for payment of per diem and travel expenses and there is to be no payment for services rendered.
- When obtaining the services of expert witnesses for litigation or special counsel to assist the County.
- When in unusual or extraordinary circumstances, the Board of Supervisors or the Purchasing Agent/Purchasing Manager determines that the best interests of the County would be served by not securing competitive bids or issuing a request for proposal.

Contracts for services should not usually cover a period of more than one year although a longer period may be approved in unusual circumstances. Multiple year contracts must include provisions for early termination and must be contingent on available funding. Unless exempted as provided for above, no contract for service shall extend, either by original contract or by extension, beyond three years unless competitive bids have been sought or a Request for Proposal has been processed.

During any competitive bidding procedure, all bids shall be opened publicly and the dollar amount of each bid shall be read aloud. Under no circumstance shall a bid which is received at the designated place of opening after the closing time be opened or considered.

Contracts for goods or services shall not be effective until approved by the Board of Supervisors or, if appropriate, the Purchasing Agent/Purchasing Manager. Contractors and vendors shall be advised by the responsible department head that performance under the contract may not commence prior to such approval.

Medical Professional Contracts

The competitive recruitment process, annual performance evaluation, and periodic salary surveys are equivalent to competitive bids for independent physicians contracting with the County on a fee for service basis.

A salary survey for physician services shall be conducted every two years.

Contracts for physician services shall not extend, either by original contract or by extension, beyond five years unless competitive bids have been sought or unless exempted as provided above.

Contracts for Legal Services

The competitive recruitment process, annual performance evaluation, and periodic salary surveys are equivalent to competitive bids for independent law firms and attorneys contracting with the County on a fee for service basis.

A salary survey for legal services shall be conducted every two years.

The selection of and contracting with firms to provide legal services shall be coordinated through the County Counsel's Office. The County Counsel shall assist in securing a law firm with the requisite legal expertise and price structure that would provide the best service to the County. County Counsel shall be involved throughout the process of selecting a firm, developing a contract, and monitoring the billing and services provided throughout the contract period.

Prohibited Bids Concerning End Product of Consulting Contracts

No person, firm, or subsidiary thereof who has been awarded a consulting services contract by the County, shall be awarded a contract for the provision of services, procurement of goods or supplies, or any other related action which is required, suggested, or otherwise deemed appropriate in the

end product of the consulting services contract. This policy may be waived by the Board of Supervisors on a four-fifths (4/5) vote finding that such waiver is in the best interests of the County.

Management Responsibility: The County Administrative Officer is responsible for preparing and issuing written procedures to assure compliance with this policy by all County officials and departments.

ADMINISTRATIVE POLICY NUMBER 71

Prohibiting the Use of Public Funds for Political Advocacy

Fresno County Administrative Policy No. 71 provides that no County assets, including money, shall be used for political campaigns of any type. Political campaigns are defined as political advocacy for or opposition to a matter or person that has qualified for the ballot. No contract entered into by the County shall provide for use of County monies for political campaigns.

Policy Statement: Government assets, including money, grant funds, paid staff time, equipment and supplies, facilities or any other government asset shall not be used for political campaigns of any type. Political campaigns are defined as political advocacy for or opposition to a matter or person that has qualified for the ballot.

Management Responsibility: Department Heads shall be held responsible for ensuring that government assets within their control are not used to advocate for or against any matter or person that has qualified for the ballot.

This section does not prohibit the expenditure of government assets to create and provide informational or educational materials regarding a matter that has qualified for the ballot. Such information or educational materials shall provide a fair, accurate and impartial presentation of relevant information relating to the matter that has qualified for the ballot. However, government assets shall not be expended to create and provide such informational or educational materials in the 90 days prior to the election unless specifically authorized by the Board of Supervisors or required by the Public Records Act or other law.

TABLE OF CONTENTS

	<u>PAGE</u>
KEY DATES	3
BIDDING INSTRUCTIONS.....	4
PARTICIPATION.....	12
LOCAL VENDOR BID PREFERENCE AND DISABLED VETERAN BUSINESS ENTERPRISE BID PREFERENCE	13
PREFERENCE CERTIFICATION LOCAL VENDOR AND/OR DISABLED VETERANS BUSINESS ENTERPRISE	15
REFERENCE LIST.....	17
EQUIPMENT GENERAL REQUIREMENTS	18
SPECIFICATIONS/REQUIREMENTS.....	19
WARRANTY	20
QUOTATION SCHEDULE.....	21
CHECK LIST	22
ATTACHMENTS	23

KEY DATES

RFQ Issue Date: February 1, 2016

Deadline for Written Requests for Interpretations or Corrections of RFQ: February 11, 2016 at 10:00 A.M.
E-Mail: CountyPurchasing@co.fresno.ca.us

RFQ Closing Date: February 24, 2016 at 2:00 P.M.
County of Fresno Purchasing
4525 E. Hamilton Avenue, 2nd Floor
Fresno, CA 93702

BIDDING INSTRUCTIONS

The County of Fresno is requesting bids for, two (2) Peterbilt bottom dump trucks, model 389.

LOCAL VENDOR PREFERENCE AND DISABLED VETERAN BUSINESS ENTERPRISE BID

PREFERENCE: The Local Vendor Preference and Disabled Veteran Business Enterprise Preference do apply to this Request for Quotation.

DEFINITIONS: The terms Bidder, Proposer, Contractor and Vendor are all used interchangeably and refer to that person, partnership, corporation, organization, agency, etc. which is offering the quotation and is identified on page one of this Request For Quotation (RFQ).

ISSUING AGENT: This RFQ has been issued by County of Fresno, Purchasing. Purchasing shall be the vendor's sole point of contact with regard to the RFQ, its content, and all issues concerning it.

INTERPRETATION OF RFQ: Vendors must make careful examination of the requirements, specifications and conditions expressed in the RFQ and fully inform themselves as to the quality and character of services required. If any person planning to submit a quotation finds discrepancies in or omissions from the RFQ or has any doubt as to the true meaning or interpretation, correction thereof may be requested in writing from Purchasing by February 11, 2016 at 10:00 A.M., cut-off.

Questions shall be delivered to County of Fresno Purchasing, 4525 E. Hamilton Avenue, Fresno, California 93702 or email: CountyPurchasing@co.fresno.ca.us.

NOTE: Time constraints will prevent County from responding to questions submitted after the cut-off date.

Any change in the Request for Quotation will be made by written addendum issued by the County. The County will not be responsible for any other explanations or interpretations.

AWARD: Award will be made to the vendor(s) offering the services, products, prices, delivery, equipment and system deemed to be to the best advantage of the County. The County shall be the sole judge in making such determination. Award Notices are tentative: Acceptance of an offer made in response to this RFQ shall occur only upon execution of an agreement by both parties or issuance of a valid written Purchase Order by Fresno County Purchasing.

RIGHT TO REJECT BIDS: The County reserves the right to reject any and all bids and to waive informalities or irregularities in bids.

AUTHORIZED CONTACT: All communication regarding this RFQ shall be directed to an authorized representative of County Purchasing. The specific buyer managing this RFQ is identified on the cover page, along with his or her telephone number, and he or she should be the primary point of contact for discussions or information pertaining to the RFQ. Contact with any other County representative, including elected officials, for the purpose of discussing this RFQ, its content, or any other issue concerning it, is prohibited unless authorized by Purchasing. Violation of this clause, by the vendor having unauthorized contact (verbally or in writing) with such other County representatives, may constitute grounds for rejection by Purchasing of the vendor's quotation.

The above stated restriction on vendor contact with County representatives shall apply until the County has awarded a purchase order or contract to a vendor or vendors, except as follows. First, in the event that a vendor initiates a formal protest against the RFQ, such vendor may contact the appropriate individual, or individuals who are managing that protest as outlined in the County's established protest procedures. All such contact must be in accordance with the sequence set forth under the protest procedures. Second, in the event a public hearing is scheduled before the Board of Supervisors to hear testimony prior to its approval of a purchase order or contract, any vendor may address the Board.

NUMBER OF COPIES: Submit **one (1) original and two (2) copies** of your quotation no later than the quotation closing date and time as stated on the front of this document to County of Fresno Purchasing. Each copy to be identical to the original, include all supporting documentation (e.g. literature, brochures, reports, schedules etc.). The cover page of each quotation is to be appropriately marked "Original" or "Copy".

FIRM QUOTATION: All quotations shall remain firm for at least one hundred eighty (180) days.

NON-FUNDING CLAUSE: Funds provided for equipment supplied under the terms of this bid are contingent on the approval of the appropriating government agency. Should sufficient funds not be allocated, the equipment or the amount of equipment to be supplied may be modified or terminated at any time.

TAXES: The quoted amount must include all applicable taxes. If taxes are not specifically identified in the quotation it will be assumed that they are included in the total quoted.

SALES TAX: Fresno County pays California State Sales Tax in the amount of 8.225% regardless of vendor's place of doing business.

TAXES, PERMITS & FEES: The successful bidder shall pay for and include all federal, state and local taxes direct or indirect upon all materials; pay all fees for, and obtain all necessary permits and licenses, unless otherwise specified herein.

SPECIFICATIONS AND EQUALS: Brand names, where used, are a means of establishing quality and style. Bidders are invited to quote their equals. Alternate offers are to be supported by literature, which fully describes items that you are bidding.

No exceptions to or deviations from this specification will be considered unless each exception or deviation is specifically stated by the bidder, in the designated places. If no exceptions or deviations are shown, the bidder will be required to furnish items exactly as specified herein. The burden of proof of compliance with this specification is the responsibility of the bidder.

LITERATURE: Bidders shall submit literature, which fully describes items on which they are bidding, not later than the closing date of this bid. Any and all literature submitted must be stamped with bidders name and address.

MERCHANDISE RETURNABLE FOR FULL CREDIT: Bidder agrees to accept for full credit any merchandise sold by him on contract or award resulting from this bid, if returned in good condition by the County.

GUARANTEE AGAINST DEFECTS: All items are to carry a full guarantee against defects in materials and workmanship and guarantee against breakage and other malfunctions when performing work for which they are designed.

VENDOR ASSISTANCE: Successful bidder shall furnish, at no cost to the County, a representative to assist County departments in determining their product requirements.

MINOR DEVIATIONS: The County reserves the right to negotiate minor deviations from the prescribed terms, conditions and requirements with the selected vendor.

QUOTATION REJECTION: Failure to respond to all questions or not to supply the requested information could result in rejection of your quotation.

BIDDERS' LIABILITIES: County of Fresno will not be held liable for any cost incurred by vendors in responding to the RFQ.

PRICE RESPONSIBILITY: The selected vendor will be required to assume full responsibility for all services and activities offered in the quotation, whether or not they are provided directly. Further, the County of Fresno will consider the selected vendor to be the sole point of contact with regard to contractual matters, including payment of any and all charges resulting from the contract. The contractor may not subcontract or transfer the contract, or any right or obligation arising out of the contract, without first having obtained the express written consent of the County.

PRICES: Bidder agrees that prices quoted are a maximum for the contract period, and in the event of a price decline such lower prices shall be extended to the County of Fresno. Prices shall be quoted F.O.B. destination.

CONFIDENTIALITY: Bidders shall not disclose information about the County's business or business practices and safeguard confidential data which vendor staff may have access to in the course of system implementation.

NEWS RELEASE: Vendors shall not issue any news releases or otherwise release information to any third party about this RFQ or the vendor's quotation without prior written approval from the County of Fresno.

BACKGROUND REVIEW: The County reserves the right to conduct a background inquiry of each proposer/bidder which may include collection of appropriate criminal history information, contractual and business associations and practices, employment histories and reputation in the business community. By submitting a quotation/bid to the County, the vendor consents to such an inquiry and agrees to make available to the County such books and records the County deems necessary to conduct the inquiry.

EXCEPTIONS: Identify with explanation, any terms, conditions, specifications or stipulations of the RFQ with which you CAN NOT or WILL NOT comply. Exceptions to items contained in the **SPECIFICATIONS/REQUIREMENTS** Section of this RFQ shall be stated in the bidder's response to that section. All other exceptions shall be stated under a separate section of the bidder's response to this RFQ. Such section shall be entitled "**EXCEPTIONS**".

ADDENDA: In the event that it becomes necessary to revise any part of this RFQ, addenda will be provided to all agencies and organizations that receive the basic RFQ.

CONFLICT OF INTEREST: The County shall not contract with, and shall reject any bid or quotation submitted by the persons or entities specified below, unless the Board of Supervisors finds that special circumstances exist which justify the approval of such contract:

1. Employees of the County or public agencies for which the Board of Supervisors is the governing body.
2. Profit-making firms or businesses in which employees described in Subsection (1) serve as officers, principals, partners or major shareholders.
3. Persons who, within the immediately preceding twelve (12) months, came within the provisions of Subsection (1), and who were employees in positions of substantial responsibility in the area of service to be performed by the contract, or participated in any way in developing the contract or its service specifications.
4. Profit-making firms or businesses in which the former employees described in Subsection (3) serve as officers, principals, partners or major shareholders.
5. No County employee whose position in the County enables him to influence the selection of a contractor for this RFQ, or any competing RFQ, and no spouse or economic dependent of such employee, shall be employees in any capacity by a bidder, or have any other direct or indirect financial interest in the selection of a contractor.

INVOICING: All invoices are to be delivered to the ordering department. Each invoice shall reference the Purchase Order/Contract number. The Contractor shall obtain the "Invoice to" address when receiving the order.

PAYMENT: The bidder agrees to provide equipment and other requirements as stated in this Request for Quotation. The County of Fresno agrees to pay bidder at the terms and conditions stated in the Request for Quotation.

Payment will be withheld until complete delivery is made by the Vendor and such delivery is accepted by County as being complete and satisfactory.

Partial payment may or may not be acceptable to the County of Fresno. Should partial payment be made by the County of Fresno, a percentage of the agreement amount shall be held until all terms and conditions of the Request for Quotations are satisfied.

PAYMENT TERMS: Payment terms are Net forty-five (45) days except when bidder offers an acceptable cash discount. The payment period shall be computed from the date that County makes final acceptance of

the equipment or from date of receipt of invoice, whichever is latest. Invoices must be submitted as stated in the Purchase Order/Contract.

ORDERING: Order will be placed as required by County of Fresno Fleet Services.

INDEPENDENT CONTRACTOR: In performance of the work, duties, and obligations assumed by Contractor under any ensuing Agreement, it is mutually understood and agreed that CONTRACTOR, including any and all of Contractor's officers, agents, and employees will at all times be acting and performing as an independent contractor, and shall act in an independent capacity and not as an officer, agent, servant, employee, joint venturer, partner, or associate of the COUNTY. Furthermore, County shall have no right to control or supervise or direct the manner or method by which Contractor shall perform its work and function. However, County shall retain the right to administer this Agreement so as to verify that Contractor is performing its obligations in accordance with the terms and conditions thereof. Contractor and County shall comply with all applicable provisions of law and the rules and regulations, if any, of governmental authorities having jurisdiction over matters the subject thereof.

Because of its status as an independent contractor, Contractor shall have absolutely no right to employment rights and benefits available to County employees. Contractor shall be solely liable and responsible for providing to, or on behalf of, its employees all legally-required employee benefits. In addition, Contractor shall be solely responsible and save County harmless from all matters relating to payment of Contractor's employees, including compliance with Social Security, withholding, and all other regulations governing such matters. It is acknowledged that during the term of the Agreement, Contractor may be providing services to others unrelated to the County or to the Agreement.

SELF-DEALING TRANSACTION DISCLOSURE: Contractor agrees that when operating as a corporation (a for-profit or non-profit corporation), or if during the term of the agreement the Contractor changes its status to operate as a corporation, members of the Contractor's Board of Directors shall disclose any self-dealing transactions that they are a party to while Contractor is providing goods or performing services under the agreement with the County. A self-dealing transaction shall mean a transaction to which the Contractor is a party and in which one or more of its directors has a material financial interest. Members of the Board of Directors shall disclose any self-dealing transactions that they are a party to by completing and signing a Fresno County Self-Dealing Transaction Disclosure Form and submitting it to the County prior to commencing with the self-dealing transaction or immediately thereafter.

HOLD HARMLESS CLAUSE: Contractor agrees to indemnify, save, hold harmless and at County's request, defend the County, its officers, agents and employees, from any and all costs and expenses, damages, liabilities, claims and losses occurring or resulting to County in connection with the performance, or failure to perform, by Contractor, its officers, agents or employees under this Agreement and from any and all costs and expenses, damages, liabilities, claims and losses occurring or resulting to any person, firm or corporation who may be injured or damaged by the performance, or failure to perform, of Contractor, its officers, agents or employees under this Agreement.

MATERIALS TO BE NEW: All materials shall be new and of merchantable grade, free from defect. No bid will be considered unless it is accompanied by a complete list of manufacturer's catalog numbers of the items, which the bidder proposes to furnish, together with full descriptive literature on all items so enumerated. If item proposed differs from these specifications, bidder shall present specific explanation of functioning and structural characteristics for those details which differ from the specifications listed herein.

DAMAGE TO EXISTING WORK: Damage to existing construction, equipment, planting, etc., by the contractor in the performance of his work shall be replaced or repaired and restored to original condition by the contractor.

CLEAN UP: The Contractor shall at all times, keep the premises clean from accumulation of waste materials or rubbish caused by his employees or work and shall remove all resulting work debris from the job site.

COORDINATE WORK WITH OWNER: Successful bidder shall coordinate and schedule the work with the County so that any interruption to the normal business operations be kept to a minimum.

INSPECTION: All material and workmanship shall be subject to inspection, examination and test by the County at any and all times during which manufacture and/or construction are carried on. The County shall have the right to reject defective material and workmanship or require its correction.

SUPERVISION: The Contractor shall give efficient supervision to the work, using therein the skill and diligence for which he is remunerated in the contract price. He shall carefully inspect the site and study and compare all drawings, specifications and other instructions, as ignorance of any phase of any of the features or conditions affecting the contract will not excuse him from carrying out its provisions to its full intent.

STANDARD OF PERFORMANCE: All work shall be performed in a good and workmanlike manner.

SAFEGUARDS: The contractor shall provide safeguards, in conformity with all local codes and ordinances as may be required.

INSURANCE: Without limiting the COUNTY's right to obtain indemnification from CONTRACTOR or any third parties, CONTRACTOR, at its sole expense, shall maintain in full force and effect, the following insurance policies or a program of self-insurance, including but not limited to, an insurance pooling arrangement or Joint Powers Agreement (JPA) throughout the term of the Agreement:

- A. Commercial General Liability: Commercial General Liability Insurance with limits of not less than One Million Dollars (\$1,000,000) per occurrence and an annual aggregate of Two Million Dollars (\$2,000,000). This policy shall be issued on a per occurrence basis. COUNTY may require specific coverages including completed operations, products liability, contractual liability, Explosion-Collapse-Underground, fire legal liability or any other liability insurance deemed necessary because of the nature of this contract.
- B. Automobile Liability: Comprehensive Automobile Liability Insurance with limits for bodily injury of not less than Two Hundred Fifty Thousand Dollars (\$250,000.00) per person, Five Hundred Thousand Dollars (\$500,000.00) per accident and for property damages of not less than Fifty Thousand Dollars (\$50,000.00), or such coverage with a combined single limit of Five Hundred Thousand Dollars (\$500,000.00). Coverage should include owned and non-owned vehicles used in connection with this Agreement.
- C. Professional Liability: If CONTRACTOR employs licensed professional staff, (e.g., Ph.D., R.N., L.C.S.W., M.F.C.C.) in providing services, Professional Liability Insurance with limits of not less than One Million Dollars (\$1,000,000.00) per occurrence, Three Million Dollars (\$3,000,000.00) annual aggregate.
- D. Worker's Compensation: A policy of Worker's Compensation insurance as may be required by the California Labor Code.

CONTRACTOR shall obtain endorsements to the Commercial General Liability insurance naming the County of Fresno, its officers, agents, and employees, individually and collectively, as additional insured, but only insofar as the operations under this Agreement are concerned. Such coverage for additional insured shall apply as primary insurance and any other insurance, or self-insurance, maintained by COUNTY, its officers, agents and employees shall be excess only and not contributing with insurance provided under CONTRACTOR's policies herein. This insurance shall not be cancelled or changed without a minimum of thirty (30) days advance written notice given to COUNTY.

Within thirty (30) days from the date CONTRACTOR executes this Agreement, CONTRACTOR shall provide certificates of insurance and endorsement as stated above for all of the foregoing policies, as required herein, to the County of Fresno, **Fleet Services, 4551 E. Hamilton Avenue, Fresno, CA 93702**, stating that such insurance coverage have been obtained and are in full force; that the County of Fresno, its officers, agents and employees will not be responsible for any premiums on the policies; that such Commercial General Liability insurance names the County of Fresno, its officers, agents and employees, individually and collectively, as additional insured, but only insofar as the operations under this Agreement are concerned; that such coverage for additional insured shall apply as primary insurance and any other insurance, or self-insurance, maintained by COUNTY, its officers, agents and employees, shall be excess only and not contributing with insurance provided under CONTRACTOR's policies herein; and that this insurance shall not be cancelled or changed without a minimum of thirty (30) days advance, written notice given to COUNTY.

In the event CONTRACTOR fails to keep in effect at all times insurance coverage as herein provided, the COUNTY may, in addition to other remedies it may have, suspend or terminate this Agreement upon the occurrence of such event.

All policies shall be with admitted insurers licensed to do business in the State of California. Insurance purchased shall be purchased from companies possessing a current A.M. Best, Inc. rating of A FSC VII or better.

EPAYMENT OPTION: The County of Fresno provides an Epay Program which involves payment of invoices by a secure Visa account number assigned to the supplier after award of contract. Notification of payments and required invoice information are issued to the supplier's designated Accounts Receivable contact by e-mail remittance advice at time of payment. To learn more about the benefits of an Epay Program, how it works, and obtain answers to frequently asked questions, click or copy and paste the following URL into your browser: www.bankofamerica.com/epayablesvendors or call Fresno County Accounts Payable, 559-600-3609.

F.O.B. DESTINATION: All bids are to be quoted F.O.B. the County of Fresno at the following address:

Fleet Services
4551 E. Hamilton Avenue
Fresno, CA 93702

DELIVERY: Prompt delivery is essential. Failure to furnish delivery as promised will constitute a breach of agreement and the County of Fresno may procure items in accordance with the General Conditions of this RFQ.

BRAND NAMES: Whenever in the specifications, any material or process is indicated or specified by patent or proprietary name and/or by name of manufacturer, such specifications shall be deemed to be used for the purpose of facilitating descriptions of the material and/or process. The bidder may offer his/her alternate equivalents if identified and accompanied by specifications. The County shall have the sole authority in determining if an alternate is acceptable.

ALTERNATES MAY BE ACCEPTED: The County reserves the right to permit deviations from the specifications if an article offered is substantially in accord with the specifications and is deemed by the County to be satisfactory for its intended use as an article fully meeting specifications. The County will be the sole judge in the determination of acceptable deviations. Unless exceptions are noted by bidder, the article offered will be assumed to be in accord with specifications.

OPERATOR TRAINING: If required, successful bidder will arrange training for an operator selected from the staff of the County of Fresno. This training is to cover basic theory, proper operations and maintenance of the unit being installed. All cost of class instruction to be borne by the bidder.

MAINTENANCE: The successful bidder shall provide all tools or minor equipment specifically required to maintain equipment supplied. Bidder shall list any special oils, additives, or other lubricants needed for maintenance of equipment supplied.

EQUIPMENT MANUALS: The successful bidder shall provide the following at or before the time of delivery of equipment:

1. Two (2) operator's manual for each unit.
2. Two (2) complete service and repair manual, including engine per group.
3. Two (2) complete parts manual, including engine per group.

Sets shall consist of one (1) hard copy and one (1) electronic set. If electronic copies are not available, two (2) hard copies shall be sufficient.

Manuals to be supplied at time of delivery. Delivery will not be considered complete and formal acceptance of equipment will not be issued until all manuals are received by the appropriate County representative.

Microfiche documents including engine are acceptable as parts manual.

REPAIRS WHILE UNDER WARRANTY: All shipping charges, mileage, charges for servicemen, parts, and labor required shall be included under warranty.

BIDDER TO COMPLETE:

Name of Insurance Carrier: _____

Public Liability: _____ Expires: _____

Automotive Insurance: _____ Expires: _____

Worker's Compensation: _____ Expires: _____

Proof of maintenance of adequate insurance will be required before award is made to vendor.

GUARANTEE: The bidder shall state his written guarantee here:

GUARANTEED PICK UP AND/OR DELIVERY: Bidder will be considered in award of bid only if they can guarantee. Enter guarantee on this line (i.e. number of days from receipt of order to delivery):

By: _____
(Authorized Signature in Blue Ink)

WARRANTY AND SERVICE LOCATION:

State the warranty and/or guarantee provisions applicable to this equipment or attach warranty form with your bid.

State specific location, where service and/or maintenance can be obtained. Failure to furnish this information will be cause for rejection of bid.

ADDITIONAL ITEMS:

The County may require additional items from those in bid schedule.

Price list for additional items:

A [] percent discount from manufacturer's enclosed price list will be allowed on purchases of all additional items.

State name of price list, indicate applicable price column and give effective date of price list here:

Prices on additional items will be based on successful bidder's firm discount prices from manufacturer's enclosed published price list.

Prices on additional items will be based on successful bidder's firm discount prices from manufacturer's current published price list. Successful bidder will be required to file any new price list that may become effective during the life of the contract with the County of Fresno Purchasing Manager within thirty (30) days of its becoming effective.

State Purchase Order mailing address:

BONDS:

PERFORMANCE BOND: The successful bidders may be required to furnish a faithful performance bond.

BONDS: The successful bidder will be required to furnish a Faithful Performance Bond and a Labor and Materials Bond in an amount equal to one hundred percent (100%) of the contract price.

BONDING COMPANY: The company issuing bonds shall be a corporate surety admitted by the California Insurance Commissioner to do business in the State of California with an A.M Best rating of B++ VIII or better.

COORDINATION AND COMPLETION: The successful bidder shall contact and meet with the County Coordinator at the job site prior to commencement and completion of any work.

Successful bidder shall complete the job as instructed and described in writing by the contract, bid or amendment. Any problem or questions that arise in the scope of work, the County must be contacted and the appropriate written amendment generated.

GUARANTEE: The successful bidder shall fully guarantee all aspects of the project for the minimum period of one (1) year. Such one (1) year period shall commence upon the date of final acceptance by County. The guarantee shall include but in no way be limited to workmanship, equipment and materials.

DISPUTE RESOLUTION: The ensuing contract shall be governed by the laws of the state of California. Any claim which cannot be amicably settled without court action will be litigated in the U.S. District Court for the Eastern District of California in Fresno, CA or in a state court for Fresno County.

DEFAULT: In case of default by the selected bidder, the County may procure the services from another source and may recover the loss occasioned thereby from any unpaid balance due the selected bidder, or by any other legal means available to the County.

ASSIGNMENTS: The ensuing proposed contract will provide that the vendor may not assign any payment or portions of payments without prior written consent of the County of Fresno.

ASSURANCES: Any contract awarded under this RFQ must be carried out in full compliance with the Civil Rights Act of 1964, the Americans With Disabilities Act of 1990, their subsequent amendments, and any and all other laws protecting the rights of individuals and agencies. The County of Fresno has a zero tolerance for discrimination, implied or expressed, and wants to ensure that policy continues under this RFQ. The contractor must also guarantee that services, or workmanship, provided will be performed in compliance with all applicable local, state, or federal laws and regulations pertinent to the types of services, or project, of the nature required under this RFQ. In addition, the contractor may be required to provide evidence substantiating that their employees have the necessary skills and training to perform the required services or work.

AUDITS AND RETENTION: The Contractor shall maintain in good and legible condition all books, documents, papers, data files and other records related to its performance under this contract. Such records shall be complete and available to Fresno County, the State of California, the federal government or their duly authorized representatives for the purpose of audit, examination, or copying during the term of the contract and for a period of at least three years following the County's final payment under the contract or until conclusion of any pending matter (e.g., litigation or audit), whichever is later. Such records must be retained in the manner described above until all pending matters are closed.

BIDDER TO COMPLETE THE FOLLOWING:

PARTICIPATION

The County of Fresno is a member of the Central Valley Purchasing Group. This group consists of Fresno, Kern, Kings, and Tulare Counties and all governmental, tax supported agencies within these counties.

Whenever possible, these and other tax supported agencies co-op (piggyback) on contracts put in place by one of the other agencies.

Any agency choosing to avail itself of this opportunity, will make purchases in their own name, make payment directly to the contractor, be liable to the contractor and vice versa, per the terms of the original contract, all the while holding the County of Fresno harmless. If awarded this contract, please indicate whether you would extend the same terms and conditions to all tax supported agencies within this group as you are proposing to extend to Fresno County.

Yes, we will extend contract terms and conditions to all qualified agencies within the Central Valley Purchasing Group and other tax supported agencies.

No, we will not extend contract terms to any agency other than the County of Fresno.

(Authorized Signature in Blue Ink)

Title

**COUNTY OF FRESNO
LOCAL VENDOR BID PREFERENCE
AND
DISABLED VETERAN BUSINESS ENTERPRISE BID
PREFERENCE**

The Local Vendor and Disabled Veteran Business Enterprise Preferences apply to this RFQ.

Whenever the Purchasing Agent purchases supplies, materials and/or equipment for the County through the use of competitive bids, the Purchasing Agent, in evaluating the price or bid for such supplies, materials and/or equipment shall determine if each bidder is a Fresno County Local Vendor (FCLV) and/or a Disabled Veteran Business Enterprise (DVBE). Bidders that are either an FCLV or a California State Certified DVBE may be granted a preference when determining the award of a bid. FCLV and DVBE, for the purposes of this section, are defined below.

A. Fresno County Local Vendor (FCLV)

1. The vendor has its headquarters, distribution point or locally-owned franchise located in or having a street address within the County for at least six (6) months immediately prior to the issuance of the request for competitive bids by the Purchasing Agent; and
2. The vendor holds any required business license by a jurisdiction located in Fresno County; and
3. The vendor employs at least one (1) full-time or two (2) part-time employees whose primary residence is located within Fresno County, or if the business has no employees, shall be at least fifty percent (50%) owned by one or more persons whose primary residence(s) is located within Fresno County.

B. Disabled Veteran Business Enterprise (DVBE)

A vendor must be certified by the State of California as a Disabled Veteran Business Enterprise (DVBE) as of the close of the competitive bid process in which they are participating. State certification as a DVBE is issued by the California Department of General Services.

Other Conditions

1. Any vendor claiming to be a FCLV as defined above, or a DVBE shall so certify in writing to the Purchasing Agent. The Purchasing Agent shall not be required to verify the accuracy of any such certifications, and shall have sole discretion to determine if a vendor meets the definition of a FCLV.
2. Any person or business falsely claiming to be a FCLV or DVBE under this section shall be ineligible to transact any business with the County for a period of not less than three (3) months and not more twenty-four (24) months as determined at the sole discretion of the Purchasing Agent. The Purchasing Agent shall also have the right to terminate all or any part of any contract entered into with such person or business.
3. In the event that the Purchasing Agent rejects a vendor's claim that they are a FCLV and/or a DVBE, and as such declares them to be ineligible, such vendor shall be entitled to a public hearing before the Board of Supervisors and a five (5) day notice of the time and place thereof.
4. This section shall not apply to contracts required by state or federal statutes or regulations to be awarded to the lowest responsible bidder or otherwise exempted from local preference.

Preferences

FCLVs and DVBEs that submit a bid within five percent (5%) of the lowest responsive and responsible bid will, under certain specified circumstances, qualify to submit a new bid within two County business days of County's notification. Such new bids must be in an amount less than or equal to the lowest responsive and responsible bid previously determined by the Purchasing Agent. If the Purchasing Agent receives new bids from qualifying FCLVs and/or DVBEs, he shall award the contract to the FCLV or DVBE that submits the lowest responsive and responsible bid. If no new bids are received, the contract shall be awarded to the

original low bidder as announced by the Purchasing Agent. The lowest responsive and responsible bid shall be solely determined by the Purchasing Agent.

The Purchasing Agent will consider the following four categories of bidder relative to the Fresno County Local Vendor Preference and the Disabled Veteran Business Enterprise Preference.

Vendor Preference Categories

- 1) FCLV – Fresno County Local Vendor as defined above.
- 2) DVBE – Disabled Veteran Business Enterprise as defined above; a DVBE is not also a FCLV unless specifically designated as such.
- 3) FCLV & DVBE – A vendor that is both a Fresno County Local Vendor and Disabled Veteran Business Enterprise as defined above.
- 4) VNP – Vendor No Preference; A vendor that is neither a Fresno County Local Vendor nor a Disabled Veteran Business Enterprise.

The following table identifies the various combinations of vendor preference categories that could be received in response to an RFQ. It also indicates when a vendor qualifies for a re-bid under either the FCLV or DVBE Preference.

The first column of the table identifies the Vendor Preference Category of the bidder that the Purchasing Agent has determined to be the lowest cost, responsive and responsible bidder. Each vendor preference category is shown in the columns to the right. The table indicates when a vendor category qualifies for a re-bid relative to the low bid category in the first column (read left to right).

Low Bid Submitted by Vendor Preference Category	FCLV & DVBE	FCLV	DVBE (Not a FCLV)	VNP
FCLV & DVBE Award to Low Bid No Re-bid Opportunity	No Re-bid Opportunity	No Re-bid Opportunity	No Re-bid Opportunity	No Re-bid Opportunity
VNP Award Subject to Preference Re-bid	May Re-bid when within 5% of low bid	May Re-bid when within 5% of low bid	May Re-bid when within 5% of low bid	No Re-bid Opportunity
FCLV Award Subject to Preference Re-bid	May Re-bid when within 5% of low bid	No Re-bid Opportunity	No Re-bid Opportunity	No Re-bid Opportunity
DVBE (Not a FCLV) Award Subject to Preference Re-bid	May Re-bid when within 5% of low bid	May Re-bid when within 5% of low bid	No Re-bid Opportunity	No Re-bid Opportunity

Applying the Preferences

In determining the award of a Request for Quotation (RFQ), the Purchasing Agent will first identify the lowest cost responsive and responsible bidder, and award will be made to that vendor when such vendor is both a FCLV and a DVBE.

If the lowest such bidder is not an FCLV, it will be determined if the Local Vendor Preference and/or the DVBE Preference are applicable to other bidders. The preferences will then apply to bids submitted by FCLVs and DVBEs that are within 5% of the designated low bid. The vendors submitting bids that are within the 5% will be granted an opportunity to submit a new bid. It must be stressed that in the event of a tie between a FCLV and a DVBE that is not a FCLV, the FCLV shall take precedence in award of the contract. This condition is necessary to remain consistent with Fresno County Charter Section 12 (h), which specifically calls for a preference to local vendors.

When the lowest responsive and responsible bidder is a FCLV, other bidders who are both FCLVs and DVBEs will have the opportunity to re-bid.

When the lowest responsive and responsible bid is from a non-local DVBE, all FCLVs will be offered a re-bid opportunity.

**PREFERENCE CERTIFICATION
LOCAL VENDOR
AND/OR
DISABLED VETERANS BUSINESS ENTERPRISE**

The Fresno County Local Vendor Preference (FCLV) and the Disabled Veteran Business Enterprise Preference (DVBE) are applicable to this Request for Quotation as previously explained.

Qualified Vendors that desire consideration as a FCLV and/or a DVBE under this RFQ must complete the "Statement of Local Vendor Certification" and/or the "Statement of DVBE Certification", each is included below, and submit it/them as a part of their quotation. Late submittals of these certification forms will not be considered. Submission of either or both certifications will qualify the vendor for treatment as a local vendor or a DVBE for purposes of this RFQ only. The certification(s) made under this RFQ do not qualify the vendor for a preference under any other RFQ.

NOTIFICATION OF RE-BID

If a vendor's bid qualifies under the Fresno County Local Vendor Preference or the DVBE Preference, the vendor will be notified of his/her opportunity to re-bid. If so notified, the Vendor must submit his/her re-bid within two County business days of notification.

Notification will be issued by e-mail or Fax, whichever is preferred by the vendor. Notification to Vendor shall be considered complete upon County's transmission of e-mail or Fax. It will be the vendor's responsibility to check his/her e-mail or Fax messages for notification. The vendor's delay in retrieval of his/her notification will not alter the two (2) County business day period allowed for re-bid submission.

FCLV or DVBE TO COMPLETE:

Indicate ONE method for notification of re-bid opportunity by providing the appropriate e-mail address or Fax number. Submit this document as a part of your quotation.

E-Mail Address or Fax Number (Identify contact person)

STATEMENT OF LOCAL VENDOR CERTIFICATION
COUNTY OF FRESNO

Qualified local vendors desiring consideration under the Fresno County Local Vendor Preference must complete the following and submit with their quotation (print or type).

I _____, _____
(individual submitting bid) (title)
of/for _____ Certify that _____
(Company Name) (Company Name)

Is a Fresno County local Vendor as defined within this RFQ and therefore qualifies for the Local Vendor Preference.

Signature (In Blue Ink) Title Date

(Print Name)

STATEMENT OF DISABLED VETERAN BUSINESS ENTERPRISE
CERTIFICATION

Qualified vendors desiring consideration under the Fresno County DVBE Preference must complete the following and submit with their quotation (print or type).

I _____, _____
(individual submitting bid) (title)
of/for _____ Certify that _____
(*Company Name) (Company Name)

Is a Disabled Veteran Business Enterprise certified by the State of California and therefore qualifies for the DVBE Preference.

State of California DVBE Certification Number: _____

Signature (In Blue Ink) Title Date

(Print Name)

*Company name on file with the State of California DVBE program.

VENDOR MUST COMPLETE AND RETURN WITH REQUEST FOR QUOTATION.

Firm: _____

REFERENCE LIST

Provide a list of at least five (5) customers for whom you have recently provided similar products/services. Be sure to include all requested information.

Reference Name: _____ Contact: _____
 Address: _____
 City: _____ State: _____ Zip: _____
 Phone No.: (_____) _____ Date: _____
 Service Provided: _____

Reference Name: _____ Contact: _____
 Address: _____
 City: _____ State: _____ Zip: _____
 Phone No.: (_____) _____ Date: _____
 Service Provided: _____

Reference Name: _____ Contact: _____
 Address: _____
 City: _____ State: _____ Zip: _____
 Phone No.: (_____) _____ Date: _____
 Service Provided: _____

Reference Name: _____ Contact: _____
 Address: _____
 City: _____ State: _____ Zip: _____
 Phone No.: (_____) _____ Date: _____
 Service Provided: _____

Reference Name: _____ Contact: _____
 Address: _____
 City: _____ State: _____ Zip: _____
 Phone No.: (_____) _____ Date: _____
 Service Provided: _____

Failure to provide a list of at least five (5) customers may be cause for rejection of this RFQ.

EQUIPMENT GENERAL REQUIREMENTS

The equipment supplied shall be new (unused), current model year production and equal in style, quality and appointments to those offered to the general public. The equipment shall be supplied with all accessories as considered standard equipment for make and model specified.

The following referenced documents of record in effect on the date of the Request for Quotation, form a part of the specifications to the extent they are applicable:

- Department of Transportation, Federal Highway Administration, Motor Carrier Safety Regulations.
- U.S. Environmental Protection Agency - Current Federal Energy Administration. Gas Mileage Guide California.
- California Vehicle Code
- Federal Motor Vehicle Safety Regulations and Standards
- California Division of Industrial Safety
- OSHA Standards
- Title 19 State Fire Marshall Code Book

Failure on the part of the bidder to comply with all requirements and conditions of the Request for Quotation and this specification may be cause for rejection of bid.

No exceptions to or deviations from this specification will be considered unless each exception or deviation is specifically stated by the bidder in the designated places. If no exceptions or deviations are shown the bidder will be required to furnish vehicles exactly as specified herein. The burden of proof of compliance with this specification is the responsibility of the bidder.

Federal Excise Tax Exemption - County of Fresno IRS Registration No. 94-73-03401K.

MANUFACTURING, MATERIAL AND DESIGN PRACTICES: It is intended that the manufacturer, in the selection of components will use material and design practices that are the best available in the industry for the type of operating conditions to which the vehicle/unit will be subjected. Suspension, wheels, tires, and other parts shall be selected to give maximum performance, service life and safety. All parts, equipment and accessories shall conform in strength, quality of material, and workmanship to recognized industry standards.

SPECIFICATION VARIANCES: If any of the equipment bid varies from the specifications, such variation(s) must be listed in writing and attached as part of the quotation under a section entitled "**EXCEPTIONS**" or in the bidder's response to the "**SPECIFICATIONS/ REQUIREMENTS**" section of this RFQ. The County of Fresno reserves the right to waive minor variations if, in the opinion of the County, the basic unit meets the general intent of these specifications.

MANUFACTURER'S STANDARD EQUIPMENT:

- a. All equipment and components listed as standard by the manufacturer for model quoted, shall be furnished, whether or not such items are detailed herein, e.g.: special wrenches, tool kits, jacks, adequate to safely lift the vehicle when loaded to rated capacity, etc. Optional equipment as necessary to meet the following requirements of these specifications shall also be supplied.
- b. Specifications on the following pages are written with the intent to meet all applicable documents, but the final certification to comply shall rest with the vendor and not the County of Fresno. Should requirements as specified not comply, the manufacturer is required to re-figure and revise the specifications to meet all laws, rules and regulations where it applies to items such as the ratings of axles, tires, wheels, brakes, batteries, cooling capacity, etc., and the County of Fresno is to be notified thereof.

Purchaser will not accept any part, component or system which is not an established standard product of the bidding manufacturer. By this is meant that any item or assembly which, relative to the supplying manufacturer's standard line of products, could be described as "first of it's kind", "experimental", "only of it's kind to be built", "especially modified to comply with specifications", "prototype", etc., shall not be acceptable. All parts and components of the system offered and delivered must conform to the manufacturer's standard production or be off-shelf available hardware production item.

SPECIFICATIONS/REQUIREMENTS

The following pages state the specifications and requirements for the equipment covered under this Request for Quotation. Bidders are instructed to respond as instructed below.

When the specification includes a size or dimensions, the bidder shall also indicate the size or dimensions of that item for the equipment they are quoting.

When a specific brand and model is listed, the bidder shall indicate if he/she is offering the same as stated or an equivalent unit. The vendor must identify the brand and model being offered as an equivalent. Include complete specifications for the equivalent offered. Such specifications should be submitted as attachments to the bidder's quotation.

WARRANTY

Submission of the manufacturer's pre-printed warranty does not exclude the bidder from responding to this section.

Bidder shall fully explain the warranty, which covers the equipment being offered. Explanation shall at a minimum include the following:

Company Name: _____

Equipment Type: _____

Brand: _____

Model: _____

- a. What is covered (labor parts, travel, repairs, preventative maintenance, inspection, calibration, etc.).
- b. What is not covered (labor, parts, travel, repairs, preventative maintenance, inspection, calibration, etc.)
- c. Events, actions, etc. that will void warranty.
- d. Warranty period.
- e. Does warranty include preventative maintenance?
- f. Is warranty service limited to specific days and hours?
- g. Who will provide Warranty Service; include name, address, and phone number.
- h. What is the response time for Warranty Service?
- i. Other components of the Warranty.

QUOTATION SCHEDULE

			UNIT PRICE
2016 Peterbilt bottom dump trucks, as specified. *(Base Unit)	1	EA	\$ _____
*Same as or equivalent to the Model 389 equipment listed under the SPECIFICATIONS/REQUIREMENTS section of this RFQ.			
Brand: _____			
Model: _____			
Delivery Fees			\$ _____
Doc Fees			\$ _____
Sales tax (8.225%)			\$ _____
Misc. Charges			\$ _____
Tire Fees			\$ _____

List below all options and features included with the price stated above:

- a. _____
- b. _____
- c. _____
- d. _____
- e. _____
- f. _____

List and quote prices for all options/accessories not included in the unit price quoted above:

	<u>DESCRIPTION</u>	<u>PART NO.</u>	<u>* PRICE</u>
a.	_____	_____	\$ _____
b.	_____	_____	\$ _____
c.	_____	_____	\$ _____
d.	_____	_____	\$ _____
e.	_____	_____	\$ _____
f.	_____	_____	\$ _____

*Do not include Sales Tax.

CHECK LIST

This Checklist is provided to assist the vendors in the preparation of their bid response. Included in this list, are important requirements and is the responsibility of the bidder to submit with the bid package in order to make the bid compliant. Because this checklist is just a guideline, the bidder must read and comply with the bid in its entirety.

Check off each of the following:

- 1. _____ All signatures must be in **blue ink**.
- 2. _____ The Request for Quotation (RFQ) has been signed and completed.
- 3. _____ **One (1) original and two (2) copies** of the RFQ have been provided.
- 4. _____ Addenda, if any, have been completed, signed and included in the bid package.
- 5. _____ The completed *Reference List* as provided with this RFQ.
- 6. _____ The *Quotation Schedule* as provided with this RFQ has been completed, price reviewed for accuracy and any corrections initialed in ink.
- 7. _____ Indicate all of bidder exceptions to the County’s requirements, conditions and specifications as stated within this RFQ.
- 8. _____ The *Participation* page as provided within this RFQ has been signed and included
- 9. _____ The *Local Vendor Bid Preference and Disabled Veteran Business Enterprise Bid Preference* section (if applicable) has been completed signed and included.
- 10. _____ *Bidder to Complete* page as provided with this RFQ.
- 11. _____ Verification of Department of Industrial Relations Contractor Registration.
- 12. _____ Verification of Contractor’s License and the Department of Consumer Affairs – Contractors’ State License Board.
- 13. _____ Specification, descriptions etc. for items offered under bidder(s) quotation.
- 14. _____ A description of the design and techniques that the bidder will use to complete the project.
- 15. _____ Lastly, on the **LOWER LEFT HAND CORNER** of the sealed envelope, box, etc. transmitting your bid include the following information:

County of Fresno RFQ No.	<u>760-5434</u>
Closing Date:	<u>February 24, 2016</u>
Closing Time:	<u>2:00 P.M.</u>
Commodity or Service:	<u>Peterbilt Dump Trucks</u>

Return Checklist with your RFQ response.

ATTACHMENTS

A. Specifications

PETERBILT

Vehicle Summary

	Unit		Chassis
Model:		Model 389	Fr Axle Load (lbs): 12000
Type:		Tractor	Rr Axle Load (lbs): 23000
Description:		389	G.C.W. (lbs): 80000
	Application		Road Conditions:
Intended Serv.:		Construction Dump-On/Off Highway	Class A (Highway) 100
Commodity:		Mining Products	Class B (Hwy/Mtn) 0
	Body		Class C (Off-Hwy) 0
Type:			Class D (Off-Road) 0
Length (ft):		0	Maximum Grade: 6
Height (ft):		0.0	Wheelbase (in): 185
Max Laden Weight (lbs):		0	Overhang (in): 31
	Trailer		Fr Axle to BOC (in): 92.8
No. of Trailer Axles:		2	Cab to Axle (in): 92.2
Type:		Bottom Dump	Cab to EOF (in): 123.2
Length (ft):		24	Overall Comb. Length (in): 247
Height (ft):		10.0	
Kingpin Inset (in):		36	Special Req.
Corner Radius (in):		2	California Registry
	Restrictions		
Length (ft):		65	
Width (in):		102	
Height (ft):		13.5	

Approved by: _____ Date: _____

Note: All sales are F.O.B. designated plant of manufacture.

Ask your dealer for a quote today, or visit our website @ www.paccarfinancial.com.

PACCAR Financial offers innovative finance, lease and insurance programs customized to meet your needs.

Unpublished options may require review/approval.

Dimensional and performance data for unpublished options may vary from that displayed in PROSPECTOR.

Printed: 12/22/2015 8:37:24 AM **Complete** Model Number: Model 389
 Effective Date: Jan 1, 2016

PETERBILT

Data	Code	Description	Weight	
Base Model				
0003891	O	Model 389		15,010
0091050	O	Mining Products		0
0093060	O	Construction Dump-On/Off Highway Truck or tractor without liftable trailing axle which carries bulk materials (excavated earth, sand/gravel, asphalt, demolition debris, etc.) and unloads by dumping out the back, over the side of the body, or out the bottom of the trailer.		0
0096100	O	Bottom Dump		0
0098010	O	California Registry Required for all vehicles that will be registered in the State of California.		0
Configuration				
0200700	O	Not Applicable Secondary Manufacturer	0	0
Frame & Equipment				
0515030	S	10-5/8in Steel Rails to 285in 10.625 x 3.45 x .313 Dimension, 1,776,000 RBM; Yield Strength: 120,000 psi. Section Modulus: 14.8 cubic inches. Weight: 1.44 lbs/inch pair	0	-111
0644000	S	EOF Tractor Tapered with Xmbr Includes kingpin cutout for steel EOF crossmember only. (If kingpin cutout desired for alum xmbrs, also use Code 0611050 Steel EOF xmbr IPO Alum EOF xmbr.)	0	0
0651010	S	Peterbilt Rear Mudflaps and Straight Hangers		0
0835860	O	Holland FW35 Fifth Wheel Top Plate		240
0870000	O	Fifth Wheel Setting Behind C/L Bogie 0in Fifth wheel setting 0" behind bogie		0
0890090	O	LH Fifth Wheel Release		0
0890250	O	Multiple Fixed Fifth Wheel Settings The installed setting must be ahead of the REAR OR FIXED SETTING and must be in 2 inch increments starting 2 inches ahead of the fixed setting and extending 18 inches forward (9 additional drillings). Also, it must be odd or even to match the REAR OR FIXED SETTING.		30
0890560	O	8.6in - 9.25in Fifth Wheel Height		99
0890760	O	Fixed Fifth Wheel, Holland FW35/FW31 Outboard		71
0899060	O	Installed Fifth Wheel Setting +6 in (For use with multiple fixed 5th wheel settings - 0890250)		0
0960000	O	Frame Mounted Deck Plate and Access Pkg, LH Side		41
Front Axle & Equipment				
1012400	S	Meritor MFS12E 12,500 lb	0	0
1111190	S	Taper Leaf Springs, Shocks 12,000 lb	0	0
1243000	S	Power Steering Sheppard M100 For use with 10,000 to 13,200 lb. axle ratings. Glidekote splines on	0	4

steering shaft extend service life of components.

1250180	S	Power Steering Reservoir Frame Mounted	0
1353540	O	PHP10 Aluminum PreSet PLUS Hubs	-187
1380070	O	Greasable Front Spring Pins	0
1380350	O	Bendix Air Cam Front HP Drum Brakes 16.5x5 Complies with reduced stopping distance regulations. For use with 10,000-13,200 lb steer axles, up to and including 40,000 lb drive axles and up to 20,000 lb lift axles. Includes high performance drum brakes, automatic slack adjusters, outboard mounted brake drums.	0
1380470	O	Meritor Wide Track IPO Standard Front Axle	5
1391390	O	Long Stroke Brakes, Front Axle	0
1391410	O	Gusseted Cam Brackets, Steer Axle	0

Rear Axle & Equipment

1511440	O	Meritor RS23-161 23,000 lb Laser factory axle alignment to improve handling & reduce tire wear. Magnetic rear axle oil drain plug captures & holds any metal fragments in drive axle lube to extend service life. Parking brakes on all drive axles for optimal performance. Cognis EMGARD® FE 75W-90 synthetic axle lube provides over 1% fuel economy improvement. Reduces wear & extends maintenance intervals, resulting in increased uptime. Provides improved fluid flow to protect components in extreme cold conditions & withstand the stress from high temperatures, extending component life.	-1,896
1616290	S	PHP10 Aluminum PreSet PLUS Hubs	0
1632650	S	Long Stroke Parking Brakes, Drive Axle(s)	0
1680490	O	Gusseted Cam Brackets, Drive Axle(s)	2
1680950	O	Stability System Not Selected or Not Available	0
1682430	O	Anti-Lock Braking System (ABS) 4S4M ABS-6. Includes air braking system.	-30
1684200	S	Synthetic Axle Lubricant All Axles Peterbilt heavy duty models include Fuel Efficient Cognis EMGARD FE75W-90 which provides customers performance advantages over current synthetic lubricants with reduced gear wear and extended maintenance intervals, resulting in increased uptime. In addition, the lubricant provides improved fluid flow to protect gears in extreme cold conditions and withstand the stress from high temperatures, extending component life.	0
1687010	S	Bendix Air Cam Rear Drum Brakes 16.5x7 Inc automatic slack adjusters & outboard mounted brake drums.	0
1703910	O	Ratio 3.91 Rear Axle	0
1816040	O	Reyco 102AR 23,000 Lb Tracking Rods, Single Drive 8.25in Low Mount. Includes heavy duty shock absorbers.	-430
1922260	O	Dash Mtd Dump Switch With Indicator Light For suspension	2

Engine & Equipment

2059938	O	ISX15 500@1800 GOV@2000 1650@1200 Family 2(2013 Emissions) Includes aluminum flywheel housing. Chevron Delo LE SAE 10W30 engine oil is specially formulated for new low emissions engines. Magnetic engine oil drain plug captures and holds any metal fragments in engine oil to extend service life. N21320 N205 120..Standard Maximum Speed Limit [LSL] N21330 N207 0...Expiration Distance N21340 P112 120..Hard Maximum Speed Limit N21350 P001 64...Maximum Accelerator Pedal Vehicle Speed N21360 P110 0...Accelerator Lower Droop N21370 P059 64...Maximum Cruise Speed	340
---------	---	---	-----

N21380	P111	0....Cruise Control Lower Droop
N21400	N203	252..Reserve Speed Function Reset Distance
N21410	N202	0....Maximum Cycle Distance
N21420	N206	10...Maximum Active Distance
N21430	N201	0....Reserve Speed Limit Offset
N21440	P015	No...Engine Protection Shutdown
N21450	P026	No...Gear Down Protection
N21460	P046	1400.Max PTO Speed
N21470	P062	No...Cruise Control Auto Resume
N21480	P068	No...Auto Engine Brake in Cruise
N21500	N209	0....Expiration Distance
N21510	P520	Yes..Enable Idle Shutdown Park Brake Set
N21520	P030	5....Timer Setting
N21530	P233	Yes..Enable Impending Shutdown Warning
N21540	P234	60...Timer For Impending Shutdown Warning
N21550	P516	35...Engine Load Threshold
N21570	P031	No...Idle Shutdown Manual Override
N21590	P230	Yes..Enable Hot Ambient Automatic Override
N21610	P172	40...Low Ambient Temperature Threshold
N21620	P173	60...Intermediate Ambient Temperature Threshold
N21630	P171	80...High Ambient Temperature Threshold

2091310	O	Engine Idle Shutdown Timer Disabled	0
2091315	O	Enable EIST Ambient Temp Override	0
2091372	O	Eff EIST NA Expiration Miles	0
2091638	O	Effective VSL Setting 65.0 MPH or Greater (USA)	0
2140200	O	CARB Engine Idling Compliance PACCAR PX-7, PX-9 and MX, Cummins ISL, ISM and ISX diesel engines will include the required factory installed serialized sticker on the drivers door to identify them as meeting the NOx idling standard.	0
2513060	S	PACCAR 160 Amp Alternator, Brushed	0
2521090	S	Immersion Type Block Heater 110-120V Standard location is center left hand under cab and includes a weather-proof cover that protects the receptacle. This pre-heater keeps the coolant in the engine block from freezing when the engine is not running.	0
2522050	S	PACCAR 12V Starter	0
2538040	S	3 PACCAR Premium 12V Dual Purpose Batt 2100 CCA Threaded stud type terminal. Stranded copper battery cables are double aught (00) or larger to reduce resistance.	0
2539410	O	Battery Jumper Terminal Mounted Under Hood LH Frame Rail. Not available with PX-7 engines.	4
2621000	O	2-Speed Fan Clutch For Frequent Start/Stops	0
2723210	O	18.7 CFM Air Compressor Furnished on engine. Teflon lined stainless steel braided compressor discharge line.	0
2812170	O	Intebrake (Furnished on Engine)	0
2922040	S	PACCAR Fuel Filter/Water Separator, Unheated With water in fuel (WIF) sensor. In addition to the fuel filter supplied with the engine.	0
3010400	O	Engine Protection Shutdown Includes oil pressure, oil temperature, coolant temperature, and intake manifold temperature.	0
3114270	S	High Efficiency Cooling System Silicone radiator & heater hoses enhance value, durability, & reliability. Constant tension band clamps reduce leaks. ClimaTech extended life coolant extends maintenance intervals which reduces maintenance costs. Anti-freeze effective to -30 degrees F helps protect the engine. Low coolant level sensor warns of low coolant condition to prevent engine damage. Radiator Size by Model: 587: 1330 sq in, 579/367 FEPTO 1325	0

sq in, 567/365/367: 1440 sq in, 384/386: 1301 sq in, 382/365 FEPTO:
1184 sq in, 389/367 HH: 1669 sq in, 348: 1000 sq in.

3212500	O	(2) 15in Ptd Air Cleaners Cowl Mounted, Painted Cap. Molded rubber air intake connections with lined stainless steel clamps seal to prevent contaminants in air intake. Stainless steel air cleaner straps, brackets, & fasteners provide a durable bright finish.	61
3282700	O	(2) Vortex SS Air Cleaner Caps Stainless Steel Grille Ipo Painted Caps	0
3365040	S	Exhaust Single RH Side Of Cab DPF/SCR RH under cab. Includes cab entry RH under cab and full round stainless steel exhaust guard.	0
3381770	O	Curved Tip Standpipe(s)	0
3387870	S	24in Ht, 5in Dia Chrome, Clear Coat Standpipe(s)	0

Transmission & Equipment

4040820	O	Fuller RTO16909ALL 11-Speed Includes external oil-to-water cooler and internal pump, severe duty rear bearing cover with shield, high capacity auxiliary drive gear bearing, oil level sight glass, 15.5in Ceramic 7-Spring Easy Pedal/3600# plate/1650 torque clutch. Synthetic lubricant to reduce friction, improve efficiency, & extend component life. Magnetic transmission oil drain plug captures & holds any metal fragments in transmission oil to extend service life. Torque limiting clutch brake. Forward Ratios: LL1-26.08, LL2-11.85, L-16.30, 1st-7.41, 2nd-5.23, 7th-1.00, 8th-0.73 / Reverse Ratios: LL-20.84, L-13.03, H-3.43	110
4210190	O	1810 HD Driveline, 1 Midship Bearing 4.5in x .180 wall tubing	105
4256100	S	Manual Shifter, Black	0
4380270	O	Remote Lube Hoses for Clutch Linkage, Release Bearing and Cross Shafts - Mounted to LH Frame Rail	6

Air & Trailer Equipment

4510760	O	Bendix AD-IS EP Air Dryer with Heater Extended Purge (for use with higher air consumption applications). An integrated system air dryer that incorporates the functions of the air dryer, purge reservoir (which increases the drying capacity), wet air tank, pressure relief valve, single check valves, and pressure protection valve for air susp and other air accessories. Includes easy-to-service spin-on dessicant cartridge.	4
4520420	O	Berg Pull Cord Drain Valve(s) - All Air Tanks	0
4540420	S	Nylon Chassis Hose	0
4543320	S	Steel Painted Air Tanks All air tanks are steel with painted finish except when Code 4543330 Polish Aluminum Air Tanks is also selected (then exposed air tanks outside the frame rails will be polished aluminum). Peterbilt will determine the optimal size and location of required air tanks. Narratives requesting a specific air tank size or location will not be accepted for factory installation. See ECAT to determine number or location of air tanks installed.	0
4544020	O	Coalescing Filter For Use With AD-IS and AD-IS-EP	0
4611140	O	12ft A&E Lines Coiled & Two 7-Way Plugs plus 3-4 ft Straight Section	8
4612800	S	Trailer Hand Valve	0
4614810	S	A&E Connections BOC/BOS with Hose Tenna	0

Tires & Wheels

5069600	O	FF: BR 14ply 11R22.5 R268 Ecopia Diameter = 41.5 inches; SLR = 19.3 inches	16
---------	---	--	----

5169430	O	RR: BR 14ply 11R22.5 M710 Ecopia Diameter = 41.8 inches; SLR = 19.5 inches	28
5190004	O	Code-rear Tire Qty 04	0
5221740	O	FF: Alcoa 883677 LVL1 22.5x8.25 Alm Whl	-50
5321740	O	RR: Alcoa 883677 LvL1 22.5x8.25 Alm Whl	-100
5390004	O	Code-rear Rim Qty 04	0

Fuel Tanks

5552070	S	26in Aluminum 60 Gallon Fuel Tank RH BOC Paddle handle filler cap with threadless filler neck. Top draw fuel plumbing reduces chance of introducing air into the fuel system during low fuel level conditions due to the central placement of fuel pickup tube. Wire braid fuel lines increase durability & reduce potential for leaks.	0
5556040	O	26in Aluminum 50 Gal Fuel Tank LH BOC Paddle handle filler cap with threadless filler neck. Top draw fuel plumbing reduces chance of introducing air into the fuel system during low fuel level conditions due to the central placement of fuel pickup tube. Wire braid fuel lines increase durability & reduce potential for leaks.	-2
5603060	O	Location RH BOC 60 Gallon	0
5604050	O	Location LH BOC 50 Gallon	0
5650310	O	Fuel Tank Fill Center Not available on under cab fuel tanks.	0
5650710	O	Locate BOC Fuel Tanks Forward As Far As Possible May Result in Filler Neck Under Sleeper.	0
5652880	O	DEF Tank Mounted RH BOC You have selected a Diesel Exhaust Fluid (DEF) tank mounted on the right-hand (passenger) side of the vehicle. Note, some retail fuel distributors have chosen to standardize on DEF dispensing pumps oriented to the left-hand (driver) side of the vehicle. Please verify your selection for DEF tank mounting.	0
5652990	O	Standard DEF To Fuel Ratio 2:1 Or Greater	0
5655019	S	DEF Tank Small	0

Battery Box & Bumper

6010030	S	Aluminum Battery Box LH Under Cab, Non-Slip Step Includes diamond pattern block shaped cover in traditional/vocational models and a smooth finish tapered cover on aerodynamic models.	0	0
6040550	S	Aftertreatment RH U/C Alum Non-Slip Cab Entry Step. DPF/SCR for diesel engines, catalyst for natural gas engines. On Models 579 specifying chassis fairings, the box will be aerodynamic.	0	0
6121090	S	Steel Bumper Deep Tapered Chromed Two tow pins.	0	0

Cab & Equipment

6510140	S	Alum Cab 123in BBC Alum Hood SFFA fenders w/polished crown, spring tilt assist. Proprietary anti-blow-down locking mechanism that keeps hood open during servicing & prevents unintentional closing. Hood latch each side secures hood to cowl. Proprietary all-alum cab is light weight & durable for long service life. One-piece roof reduces potential for leaks. Two-piece windshield for cost effective windshield replacement. Lap seam construction & aircraft fasteners has greater clamp load than rivets. Bulkhead style doors provide virtually water-tight, rattle-free performance. Extruded alum door frames for strength & durability. Full length, heavy-duty piano-type stainless steel door hinges & pins provide durability. View window in RH door for safety. Electric windshield wipers & washers w/intermittent wiper function. Grab handles mtd on cab LH & RH for cab access. Convex mirror over RH door & below each rear view mirror for improved visibility & safety.	0	0
---------	---	--	---	---

6540120	O	Severe Service Cab Package #1 Includes Aluminum side skins, aluminum rear skin, steel windshield mask, steel firewall, and steel front floor sheet on all cabs, and additional reinforcement structure on the back wall of the day cab.	48
6540160	O	Thermal Insulation Package in Cab Includes thick, closed-cell foam in floor, special mylar-faced foam in walls and roof structure.	2
6911700	S	Peterbilt UltraRide Driver Seat	0
6921700	S	Peterbilt UltraRide Passenger Seat	0
6930800	O	Black Seat Color ipo Standard Color	0
6939400	S	Air Ride Driver	0
6939420	S	High Back Driver	0
6939470	S	Vinyl Driver	0
6939500	O	Air Ride Passenger	0
6939540	O	Low Back Passenger	0
6939570	S	Vinyl Passenger	0
7000350	O	Power Door Locks Both Doors	2
7001520	O	Adjustable Steering Column - Tilt/Telescope	11
7001620	S	Steering Wheel with Peterbilt Logo Steering Wheel with embossed Peterbilt logo over horn button.	0
7039050	S	ProBilt Interior - Arctic Gray Includes rugged charcoal instrument panels, gray dash with glare-resistant, charcoal soft-touch upper, dark gray hard trim, black bezels on gauges, cigar lighter and ashtray with power port, monochromatic dark gray durable doorpads with map pocket on driver's side, dark gray molded back wall, 18 inch 4-spoke soft-touch steering wheel, soft-touch steering column cover, power lift passenger window, extruded rubber floor covering, header-mounted domelight, driver and passenger dome/reading lights, footwell lighting, integrated "dead pedal", (5) inside entry grab handles, (2) inside sunvisors, (2) coat hooks, cup holder and map bin in dash.	0
7210420	O	Dark Window Tint ipo STD Tint - Day Cab	0
7210430	O	Extended Rear Window ipo Std Window-Day Cab The extended rear window protrudes two inches more than the standard conventional rear cab window. Take this into consideration when determining your loadspace.	0
7210540	S	Day Cab Rear Window	0
7230350	O	Two Piece Flat Windshield	0
7230680	O	Power Lift Windows - Both Doors For use with ProBilt or Prestige Interior	0
7322010	S	Combo Fresh Air Heater/Air Conditioner With radiator mounted condenser, dedicated side window defrosters, Bi-Level Heater/Defroster Controls, 54,500 BTU/HR, and silicone heater hoses.	0
7410040	O	Outside Sunvisor - Stainless Steel Available for Day Cab and Low Roof Sleeper.	4
7511010	O	Stainless Steel Mirrors 7x16 with Heat Element Right Click on Option to see Picture in Product Portfolio.	2
7560850	S	(2) Convex 8 Inch SS Mirror Center mounted under mirror bracket. If rear view mirrors are heated, the convex mirrors will be heated. Option includes dual door stops.	0
7620620	O	(2) Air Horns 24.5in Chrome - Round w/Horn Shield	8
7725710	O	Standard Speaker Package For Cab (2) Speakers	4
7725715	O	ConcertClass Without CD, Includes BT Phone and Audio, AM/FM, WB, USB and MP3.	10
7740100	O	Cobra 40 Channel CB Radio w/Integral Speaker	11

Includes illuminated front panel.

7748520	O	CB Antenna Mounting, Vertical, Center BOC or BOS	0
7749110	O	Mount CB Speaker LH Rear Corner Cab Headliner	2
7782230	O	Radio Antenna Mounted Logger Style Antenna Mounted LH on BOC In Place of Center Roof position on Conventional Models. Models 579 and 567 Antenna Mounted LH Roof In Place Of Center Roof position.	0
7850210	O	Plug-In Auto Reset Circuit Breaker in place of fuses in junction box.	0
7851040	O	Removable Bugscreen Behind Grille	2
7851480	S	Peterbilt Electric Windshield Wipers With Intermittent Feature.	0
7851970	O	Unibilt Cab Air Suspension Includes dual air bag suspension, leveling valve, and tracking rod.	25
7900090	O	Triangle Reflector Kit Shipped Loose	13
7900270	O	5 lb 3A:40bc Fire Extinguisher Cab Mounted	8
7901130	O	Backup Alarm (107dB)	3
8011100	O	Main Transmission Temperature Gauge	0
8011210	O	Axle Temperature Gauge, Single Drive	0
8021380	S	Air Restriction Indicator Mounted on air cleaner or intake piping.	0
8071750	O	(2) Electric Dump Switches, Bottom Dump Trailer Wired to Berg 4-way socket at BOC/BOS (To operate Bottom Dump trailer gate)	8
8071870	S	Main Instrumentation Panel, Graphics Display Includes speedometer with tripodometer, tachometer with hourmeter and outside air temperature display, voltmeter, engine oil pressure, engine coolant temperature, fuel level, primary and secondary air pressure gauges. Includes standard warning light package: high water temperature, low oil pressure, and low air pressure warning lights w/audible alarms, high beam, turn signal, low fuel, parking brake, and ice warning indicators; seat belt reminder; rocker switches with long-life LED indicators; multi-function turn stalk with flash-to-pass feature (night mode flashes headlights and marker lights; day mode flashes headlights only), intermittent windshield wiper and headlamp beam control. Hydraulic braked trucks do not include air pressure gauges.	0
8111140	S	Headlights Projector Module Pod Integral Turn Signals	0
8121170	O	(5) Marker Lights, Bus LED Bullet Light Emitting Diodes	0
8140060	O	(2) LED Stop/Turn/Tail, (1) LED Backup Inset tractor taper EOF crossmember	0
8140490	O	Additional LED Round Turn Signal Mirror Mounted	2
8151130	O	(2) Load Lights, Flush Mounted Low Inboard Loc A	4

Paint

8500710	O	Standard Paint Color Selection	0
8530770	S	(1) Color Axalta Two Stage - Cab/Hood Base Coat/Clear Coat N85020 A - L0006EB WHITE - Stand N85400 HOOD TOP L0006EB WHITE - Stand N85500 CAB ROOF L0006EB WHITE - Stand N85200 FRAME N0001EA BLACK N85300 FENDER L0006EB WHITE - Stand N85720 SK FAIRINGS L0006EB WHITE - Stand	0

Options Not Subject To Discount

9408904	<input type="radio"/>	Heavy Duty Emissions Surcharge	0	0
---------	-----------------------	---------------------------------------	---	---

Miscellaneous

9409000	<input type="radio"/>	Day Cab / ProBilt Interior (DB)	0	0
---------	-----------------------	--	---	---

9409960	<input type="radio"/>	Presentation Created Using Featured Spec For Model	0	0
---------	-----------------------	--	---	---

Total Weight				13549
--------------	--	--	--	-------

Prices and Specifications Subject to Change Without Notice.

Unpublished options may require review/approval.

Dimensional and performance data for unpublished options may vary from that displayed in PROSPECTOR.

Printed: 12/22/2015 8:37:24 AM

Complete

Model Number:

Model 389

Effective Date: Jan 1, 2016



Horizontal Dimensions

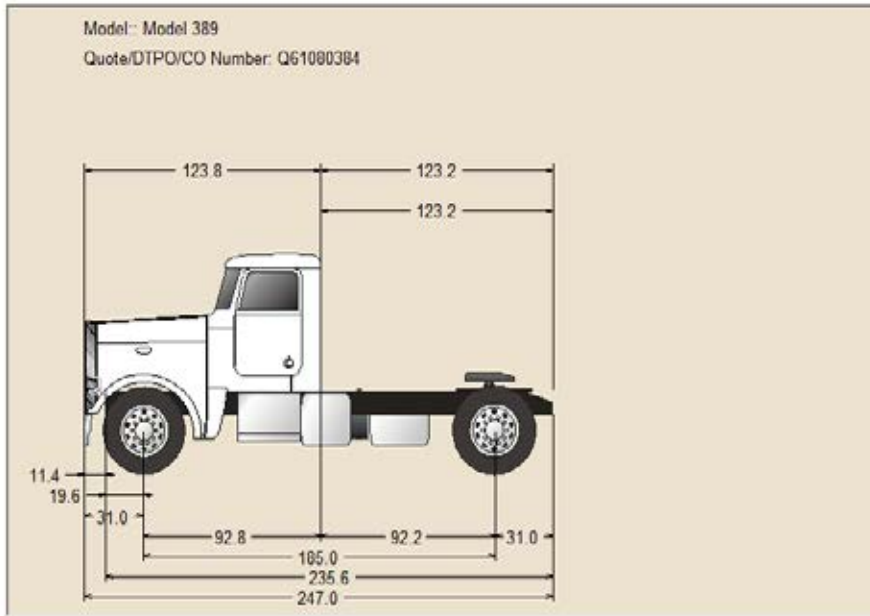

Unpublished options may require review/approval.
Dimensional and performance data for unpublished options may vary from that displayed in PROSPECTOR.

Printed:	12/21/2015 4:14:13 PM	Complete	Model Number:	Model 389
Effective Date:	Jan 1, 2016		Quote/DTPO/CO:	Q61080384
Prepared by:	ID: randyray		Version Number:	32.00